

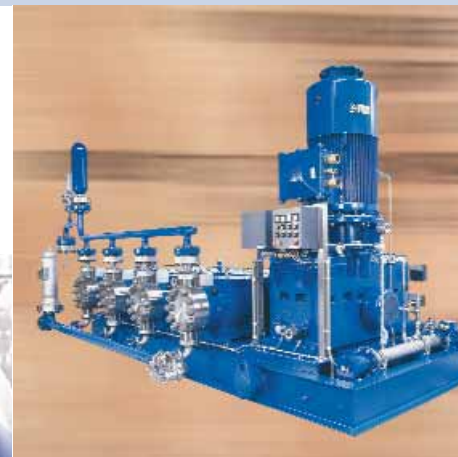

SPX Process Equipment

NOVAPLEX Process Pumps



High Performance

NOVAPLEX – Flexible high performance diaphragm pumps for high flow rates and pressure

NOVAPLEX pumps are powerful diaphragm process pumps for a variety of applications. They are best suited for critical high pressure installations. Additionally, they can be used when the capability of classical metering pumps is exceeded.

Utilization of Bran+Luebbe metering pump technology allows the process pumps to be used even as metering pumps for high flow rate and pressure.

Diaphragm pump technology

Diaphragm pumpheads of NOVAPLEX pumps are utilizing the principle of hydraulic actuation of diaphragms. The plunger movement induced by the crank gear acts on hydraulic fluid rather than the process fluid directly. The hydraulic fluid in turn displaces a freely moving diaphragm. This diaphragm acts as a hermetic seal that separates the hydraulic fluid from the pumped liquid. There are no dynamic seals between liquid and environment, consequently securing zero leakage much easier.

Applications

NOVAPLEX Pumps are ideal for toxic or chemically aggressive liquids, and for slurries/suspensions with particle sizes up to 100 µm.

Typical industrial fields are the chemical and petrochemical industry, the Oil&Gas industry, the pharmaceutical industry and also the food industry.

Examples of liquids (except of several hundred successfully pumped)

- Ammonia
- Butane
- Hydrocarbon condensate
- Latex emulsion
- Liquid CO₂
- LPG
- Methanol
- Naphtha
- Raney Nickel Suspension
- Sulphuric acid
- Toluene
- Water

Examples of pump duties

- Reactor feed pump
- High pressure injection pump
- Transfer pump
- Re-circulation pump

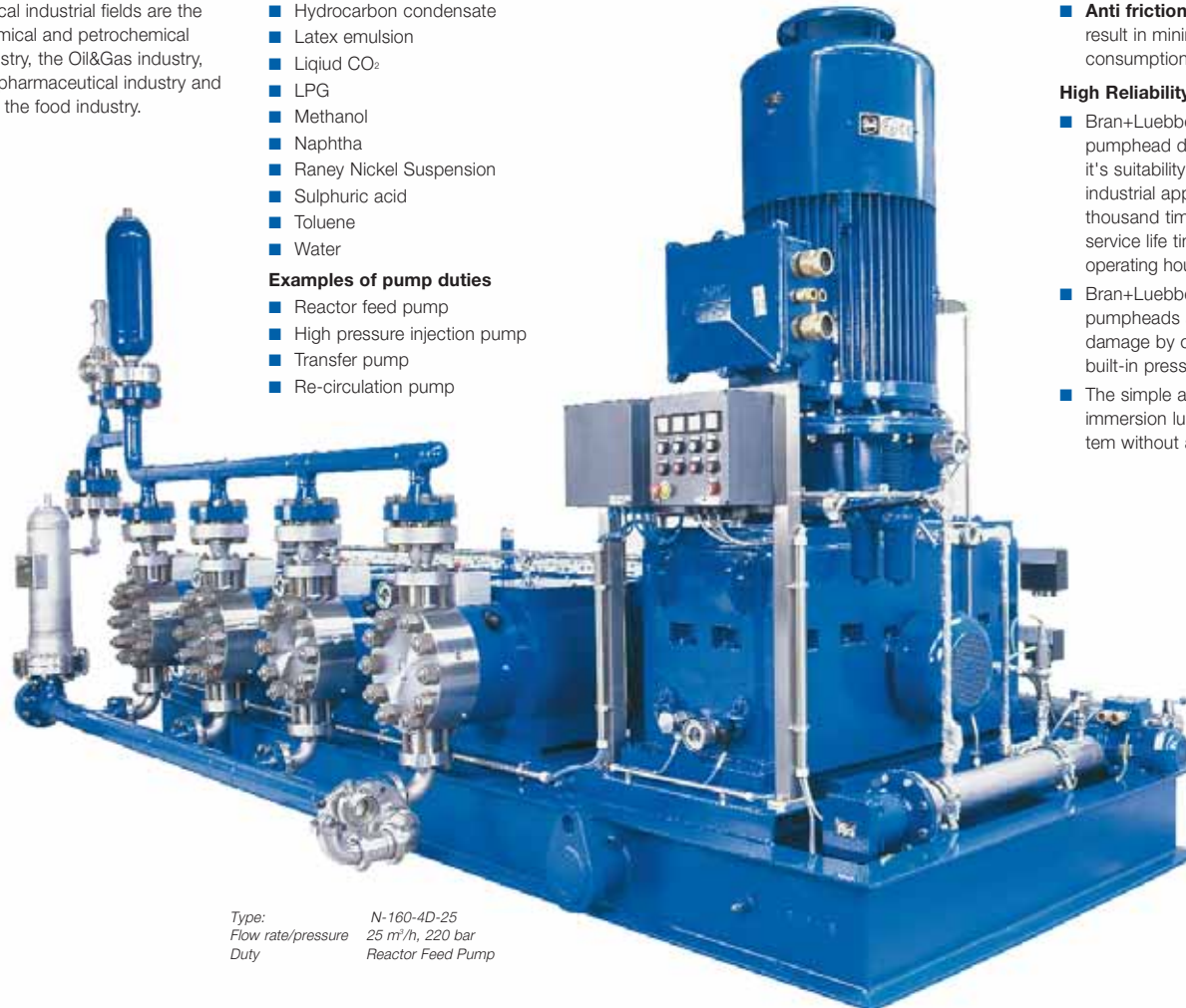

Type: N-160-4D-25
Flow rate/pressure: 25 m³/h, 220 bar
Duty: Reactor Feed Pump

Advantages

Excellent Emission Control

- Double diaphragm design offers double containment against product leakage.
- **Anti friction bearings** result in minimized energy consumption.

High Reliability

- Bran+Luebbe diaphragm pumphead design has proven its suitability for severe industrial applications several thousand times. A diaphragm service life time of 20.000 operating hours is no exception.
- Bran+Luebbe diaphragm pumpheads are save against damage by overload due to built-in pressure relief valve.
- The simple and well-proven immersion lubrication is a system without any wear parts.

Simplified Maintenance

- All pumpheads are equipped with interface for off-line diagnosis system.
- Modular concept allows easy access to any part of the pump.

Minimized Life Cycle Cost

- The exclusive use of anti-friction bearings reduces energy consumption to almost theoretical minimum.
- No measures needed to control emission of pumped liquid due to diaphragm concept. Zero leakage is an inherent property of this pump.

Features of the pump

- Double diaphragm pumpheads with positive diaphragm position control
- Double diaphragm pumpheads with built-in pressure relief valve
- Crank gears with integrated lubrication system
- Crank gear bearings executed as anti-friction bearings
- Modular concept

NOVAPLEX – Function diaphragm pumpheads, gears

Function of a diaphragm pumphead with positive diaphragm position control

The patented Positive Diaphragm Position Control (PDPC) system ensures that the diaphragm cannot be damaged even under critical conditions such as a blocked pipes or closed valves on both suction or discharge side.

The replenishing valve is activated only when the diaphragm is fully retracted at the end of the suction stroke; the diaphragm itself releases the replenishing valve interlock mechanism by pushing a control pin.

A pressure relief valve within the hydraulic system of the pump head protects not only the pump head but also the pump gear from overload due to excessive pressure.

This protection system allows clean liquids of low up to high viscosity as well as dirty fluids and all types of suspensions to be pumped safely.

Furthermore, the integrated air bleed valve "bleeds" out a small amount of hydraulic fluid and entrapped air with each pumping stroke from the hydraulic chamber, thus ensuring high metering accuracy and reproducibility.

Advantages of Positive Diaphragm Position Control (PDPC)

- Increased diaphragm life compared to non-positive control systems
- Diaphragm protection even under critical operating conditions
- High metering reproducibility due to constant hydraulic volume and permanent de-aeration of the hydraulic fluid

- Vacuum operation possible
- Dry running capabilities

Additional features of double-diaphragm pumpheads

Due to their design - featuring a diaphragm condition monitoring system in conjunction with two adjacent diaphragms - double-diaphragm pumpheads offer higher operation security than single diaphragm pumpheads.

In case of one ruptured diaphragm the pumped liquid is prevented from contamination with hydraulic fluid and, vice versa, the hydraulic fluid from contamination with pumping fluid. Also, containment of the pumped liquid is still assured

therefore avoiding the immediate need for shutting the pump down.

The diaphragm condition monitoring system is based on pressure measurement. A thin circular disc with a capillary system is positioned between the two diaphragms and connects the evacuated interstitial space with the monitoring system. Should either one of the diaphragms be ruptured, the pressure in the interstitial space and the capillary rises. It can be signalled externally by a variety of optional indicating devices such as pressure gauges, pressure switches or pressure sensors.

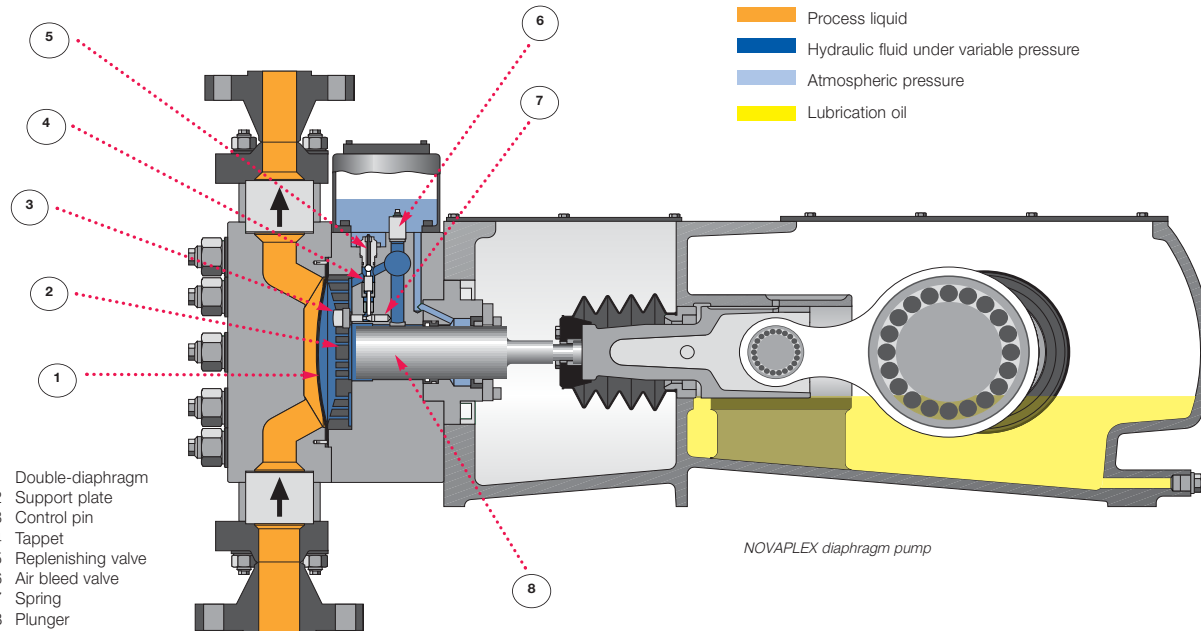

Equipped to your requirements

Pump head technology

- Hydraulically actuated PTFE double-diaphragm (up to 400 bar)
- Hydraulically actuated stainless steel double-diaphragm (up to 1000 bar)
- Pump head and valve housing in stainless steel. Special materials available for individual applications

Multi-head pumps

- Depending on the required flow rate and delivery characteristics, multi-head pumps can be supplied with 2, 3, 4, 5, 6 or 7 pumping elements. The optimum number depends on the physical characteristics of the pumped liquid.

Flow rate adjustment

Infinitely variable flow rate adjustment is achieved by varying the pump stroking speed

- AC motor with frequency converter (preferred)
- All other types of variable-speed drive

NOVAPLEX crank gear technology

- The modular concept of NOVAPLEX pumps allows multiplex pumps with up to 7 pumping elements.
- The exclusive use of anti friction bearings allows to run the pump continuously at rotational speed from almost zero up to maximum, even at extremely elevated suction pressures.

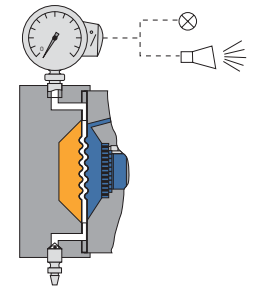

Air bleed screw with hose fitting

Free choice of drives

A further advantage of the modular concept is that all types of drive, including electric motors, combustion engines and hydraulic drives can be utilized.

The positioning of the drive depends on individual installation requirements and is to customer specification. Different gears are available, including bevel types.

The flow rate is adjustable via the rotational speed of the drive. Asynchronous AC motors with frequency converters are particularly economical, but other types of speed regulation may also be used.



Example of control cabinet

Layout and dimensions

Example: Triplex version

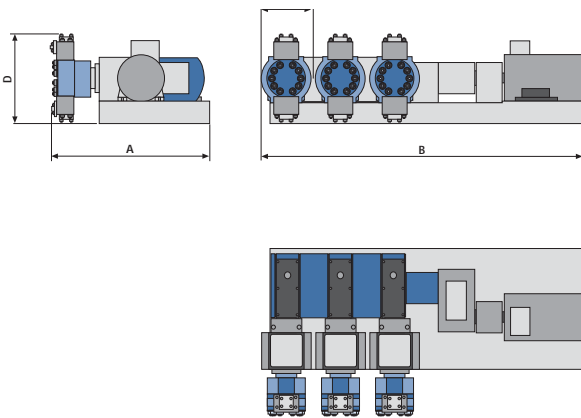

Horizontal motor position with helical gear

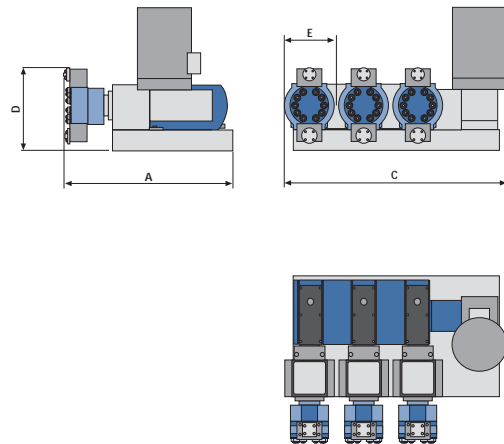

Vertical motor position with bevel gear

Main dimensions in mm*

NOVAPLEX	A	B	C	D	E
N-020-3D	1200	2500	1800	800	410
N-040-3D	1600	3000	2100	1000	520
N-080-3D	2000	3700	2700	1200	660
N-160-3D	2200	4400	3300	1300	820

* Dimensions are reference figures only. Exact dimensions depend on the size of pump head, motor and gear.

Performance graph of NOVAPLEX Triplex pumps with PTFE-diaphragm

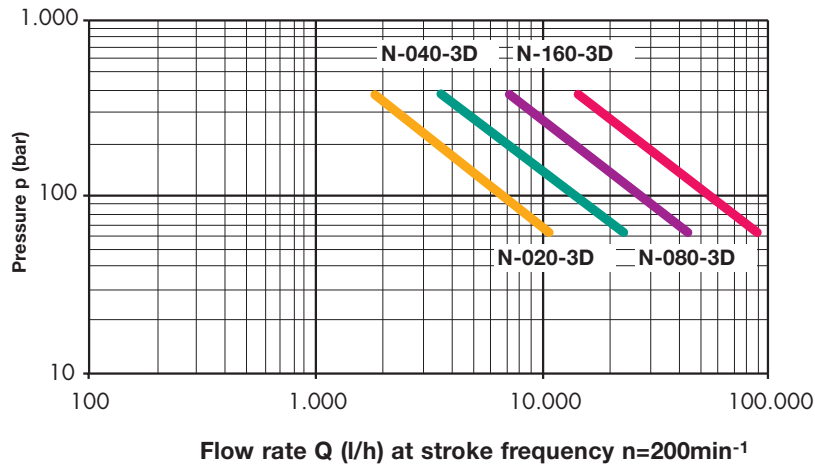

Selection of NOVAPLEX pump combinations

Three to seven pump units may be combined.

Type	Nominal pressure bar	Flow rate Q (theoretical) *		
		Triplex l/hl/h	Quadruplex l/h	Quintuplex
020	400	1740	2320	2900
	250	2710	3620	4520
	160	4240	5650	7070
	100	6730	8980	11220
	63	10860	14480	18100
040	400	3660	4890	6110
	250	5730	7630	9540
	160	8870	11820	14780
	100	13850	18470	23090
	63	22900	30540	38170
080	400	7070	9420	11780
	250	11220	14960	18700
	160	18100	24130	30160
	100	28270	37700	47120
	63	44180	58900	73630
160	400	14030	18700	23380
	250	22620	30160	37700
	160	35340	47120	58900
	100	55220	73630	92040
	63	90480	120640	150800

* Volumetric efficiency $\eta = 100\%$, stroke frequency $n = 200\text{min}^{-1}$

Note: Allow for liquid transmission losses.

Global Headquarters: SPX Process Equipment, Delavan, WI USA

How To Contact Us:

For technical details on products and services available from **SPX Process Equipment**, contact us at: www.spxprocessequipment.com



Bran+Luebbe, Norderstedt,

Werkstraße 4
D-22844 Norderstedt, Germany
Phone: +49 (0) 40 - 522 02-0
Fax: +49 (0) 40 - 522 02-444

Lightnin, Rochester

135 Mt. Read Blvd.
Rochester, NY 14611 U.S.A.
Phone +1 (585) 436 5550
Fax +1 (585) 436 5589

Waukesha Cherry-Burrell, Delavan

611 Sugar Creek Rd.
Delavan, WI 53115
Phone +1 (262) 728 1900
Fax +1 (262) 728 4904

Your local contact

