



**B+L Electric Stroke Adjustment
(RCS Electric Actuator + Smart Controller Card)
Operating Manual**

**Read and understand this manual
prior to installing, operating or servicing this equipment**



611 Sugar Creek Road
Delavan, WI 53115 USA

Tel: 800-252-5200 / 262-728-1900
Fax: 800-252-5045 / 262-728-4904
E-mail: spxpe@spx.com
www.spxpe.com

Changes to this document are made periodically. Changes, technical inaccuracies, and typographical errors will be corrected in subsequent editions. Information contained in this manual is subject to change without notice and does not represent a commitment on the part of SPX Corporation. No part of this manual may be reproduced or transmitted in any form or by any means, electronic or mechanical, including photocopying and recording, for any purpose, without the express written permission of SPX Corporation.

Copyright © 2007, 2008 SPX Corporation
All Rights Reserved

The Electric Actuator Smart Controller (EASC) is provided to SPX Process Equipment by RCS/Dresser Corporation.

Portions of this manual are drawn directly from RCS/Dresser Corporation manuals covering this product.

Issued Date: October 2008

Publication: 95-04002

Section 1.0 Controller Information	4
1.1 General.....	4
1.2 Electric Stroke Adjustment	4
1.2.1 Actuator specifications	4
1.2.2 When should the electronic positioner be recalibrated?.....	5
1.2.3 Adjusting the limit switches.....	5
1.2.4 Reinstalling the actuator	5
1.2.5 RCS actuator, NEMA 4 enclosure	6
1.2.6 RCS actuator, NEMA 7 enclosure	7
Section 2.0 Installation.....	8
2.1 Factory Installation	8
2.2 Mounting Procedure if not factory-installed.....	8
2.3 Mounting Procedure if replacing APC cards	8
2.4 Connection Diagram.....	9
2.5 Analog Connections	10
Section 3.0 Card Setup Procedure	11
3.1 General.....	11
3.2 Basic Set Up.....	11
3.3 Reloading Factory Default Settings.....	13
3.4 Setting non-Standard Input/Output Ranges	13
3.5 Selecting an Alternate Fail Position on Loss of Command Signal	14
Section 4.0 Automatic Calibration	15
Section 5.0 Card Settings	16
5.1 Basic.....	16
5.2 Advanced.....	17
Section 6.0 Available Controller Menus	19
6.1 Basic.....	19
6.2 Advanced.....	20
Section 7.0 Parts Available	22
7.1 Actuators with EASC Cards installed	22
7.2 EASC Card Kits and Associated Parts.....	22
Section 8.0 Wiring terminal changes for converting APC to EASC Installation	23
Section 9.0 Quick Set Up Information	24
9.1 Connection Diagram.....	24
9.2 General information for Quick Set Up	24
9.3 Quick Set Up	25
9.4 Reloading Factory Default Settings.....	26
9.5 Automatic Calibration	27
9.6 Basic Card Settings.....	28
Section 10.0 Reference Diagrams	29

Section 1.0 Controller Information

1.1 General

The RCS Electric Actuator Smart Controller (EASC) card is designed to provide electric stroke length adjustment capability using a 4-20 mA or a 0-10, 1-5, 2-10 V DC positioning signal to the card. The card can self-calibrate to the feedback potentiometer by driving to the extreme up and down positions to define the zero and span for position control. The controller will handle the 20-, 30-, and 60-turn metering pumps provided by Bran+Luebbe.

This manual provides the information needed to properly set up and operate the EASC card when installed to control the RCS stroke length actuators provided by Bran+Luebbe for metering pump applications. Any use of the EASC card for other purposes is not covered in this document.

For a factory-installed EASC card, the stroke length assembly is calibrated to the customer specifications and tested by Bran+Luebbe before the actuator assembly leaves Bran+Luebbe's facility, and does not normally need to be recalibrated. The EASC should be recalibrated if the assembly does not react properly when input is applied.



WARNING: In explosive atmospheres, do not remove the actuator cover while circuits are live.

1.2 Electric Stroke Adjustment

A worm wheel and crank gear inside the pump gearbox move a plunger via a connecting rod and crosshead. The length of this movement is called the stroke length and it is adjustable (electrically in this case) between 0% and 100% of maximum stroke. The electric stroke length adjustment unit can be broken into two major components, the actuator and the EASC card.

The Actuator is available in either NEMA 4 (Watertight) or NEMA 7 (Explosion-proof, indoor duty) enclosures. These actuators are fitted with a local position indicator (NEMA 4).

The EASC card will fit into either the NEMA 4 or NEMA 7 actuator enclosure. The card will control the stroke length based on an analog signal, current or voltage that is proportional to the 0-100% position, and provide an analog signal, current or voltage that is proportional to the actual rotational position.

1.2.1 Actuator specifications

Model	RCS	RCS	RCS	RCS
Gearbox type	P/H1	J/K/H2/H3	C/D/H4	CS/DS/H5/H6
Output torque (lb./inch)	250	250	250	250
Seconds for 100% stroke travel	40	60	120	120
RPM	30	30	30	30
Turns	20	30	60	60
Volts/Hertz	115/60, 50	115/60, 50	115/60, 50	115/60, 50
2 cam-operated limit switches	5 amps @ 125VAC			
Permanently lubricated?	Yes	Yes	Yes	Yes
Current amps	2.0	2.0	2.0	2.0
Duty/cycle Max on/Min off (sec.)	120/460	120/460	120/460	120/460
Conduit connection	3/4" NPT	3/4" NPT	3/4" NPT	3/4" NPT
Ambient temperature limits	-40°F to 150°F	-40°F to 150°F	-40°F to 150°F	-40°F to 150°F

1.2.2 When should the electronic positioner be recalibrated?

Before it was shipped, this positioner was calibrated to customer specifications and tested in Bran+Luebbe's factory. It *does not* automatically need to be recalibrated. You *should*, however, recalibrate the positioner if the Smart Card does not Zero or Span properly when input is applied. See page 11 for further information.

1.2.3 Adjusting the limit switches

- The limit switches are factory-set and should not be readjusted unless you are rebuilding the actuator.
- Limit switches should be adjusted only after the actuator is removed from the pump.
- Understroking or overstroking can severely damage your pump.

20-turn actuators: Cam E and limit switch E are minimum position. Cam D and limit switch D are maximum position. See pages 6 and 7 for location.

30- and 60-turn actuators: Cam D and limit switch E are minimum position. Cam E and limit switch E are maximum position.

1. Remove the actuator from the pump and take off the actuator cover.
2. Drive the actuator until the minimum cam contacts the minimum limit switch. The actuator will shut off. Make sure the clamping screw on the minimum cam is tight.
3. If applicable, set the position potentiometer at minimum position.
4. Increase the actuator the correct number of turns for your type of pump, as indicated in the table on page 4. Mark the output shaft to help you count revolutions. Loosen the clamping screw on the maximum cam until it is finger-tight. Move the maximum cam until it contacts the maximum limit switch. The actuator will shut off at this position. Retighten the screw.
5. Repeat steps 2 through 4 until the actuator moves the correct number of turns between limit switches.
6. The actuator should not turn under the minimum or over the maximum set points.

1.2.4 Reinstalling the actuator

1. Make sure the pump is mechanically zeroed. There should be no plunger movement when the drive motor is running.
2. Zero the actuator. The minimum cam should contact the minimum limit switch.
3. Mount the actuator to the pump. Tighten all bolts and nuts evenly, taking care to center the actuator on the adapter flange.
4. Remove the manual declutching knob by loosening the socket set screw.
5. Unscrew the socket head bolts on the cover and remove.
6. Wire per diagrams on pages 9, 29 and 30.
7. Run the unit back and forth several times between minimum and maximum stroke to check for binding.

1.2.5 RCS actuator, NEMA 4 enclosure

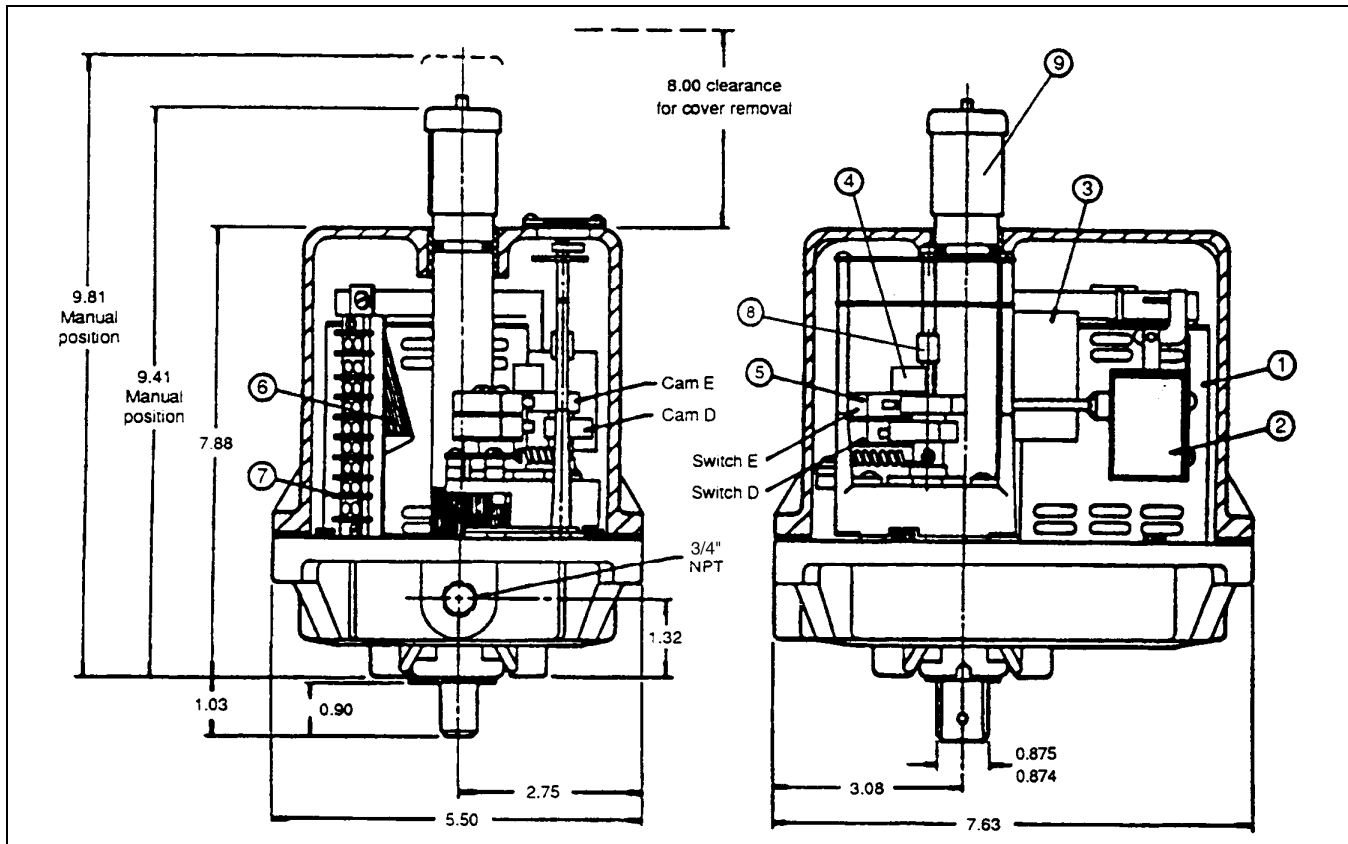

Figure 1 - NEMA 4 Enclosure

Technical Data, NEMA 7 and NEMA 7 actuators	
1.	Voltage: 120VAC, 60/50Hz, single phase
2.	4:1 duty cycle (2 minutes max. run time)
3.	Limit switches: 5A, 120 VAC "L" (amp load)
4.	Ambient temperature: -40°F to 150°F
5.	Lubrication: High-temperature grease for gears, self-lubricating bearings

Item number	Description
1	Motor
2	Brake solenoid
3	Capacitor
4	Position potentiometer
5	Limit switch
6	Resistor
7	Terminal block
8	Adjustment sleeve
9	Declutching knob

1.2.6 RCS actuator, NEMA 7 enclosure

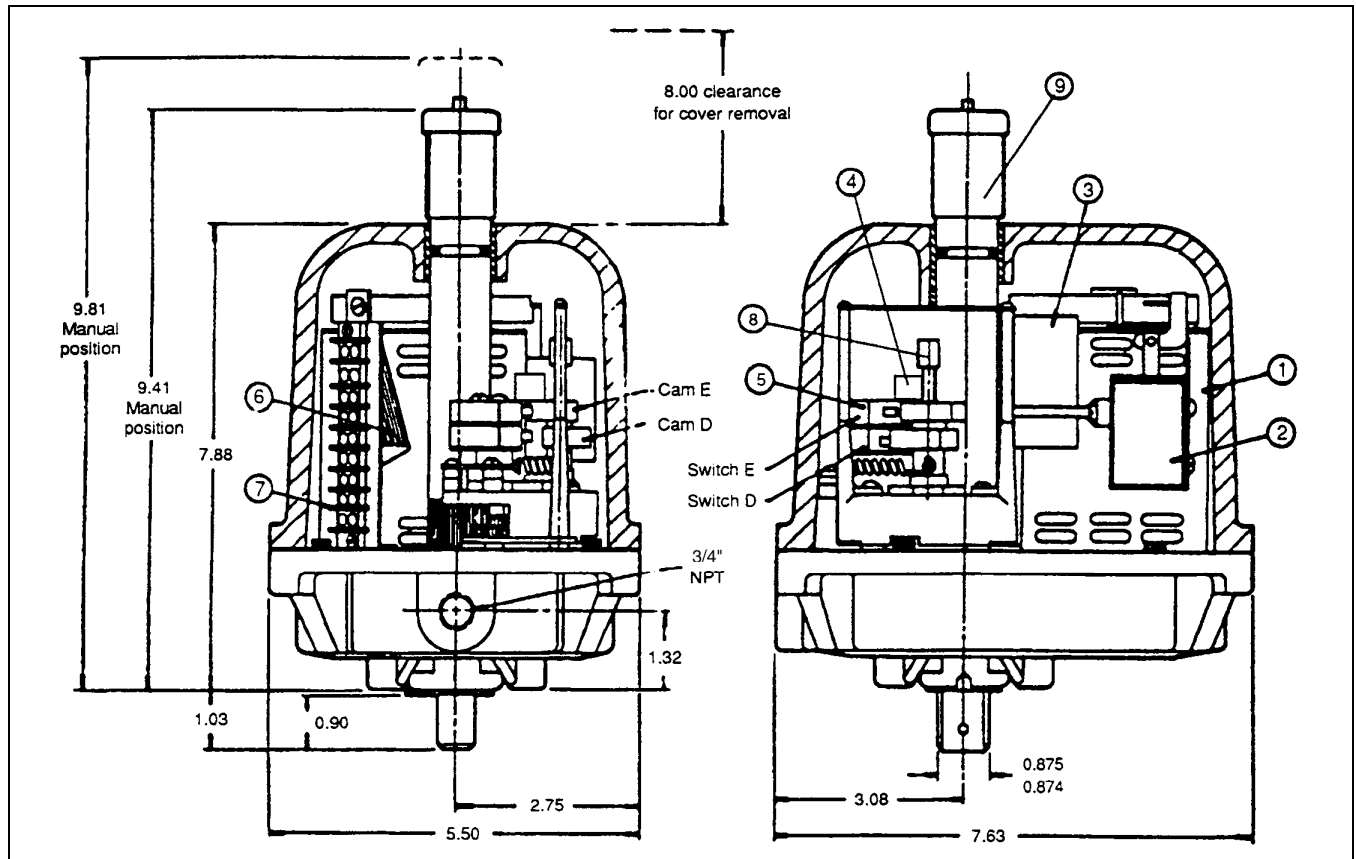

Figure 2 - NEMA 7 Enclosure

Item number	Description
1	Motor
2	Brake Solenoid
3	Capacitor
4	Position potentiometer
5	Limit switch
6	Resistor
7	Terminal block
8	Adjustment sleeve
9	Declutching knob

Manual operation, NEMA 4 and NEMA 7 actuators
1. Pull the declutching knob up and hold.
2. Put a wrench on the flats.
3. Twist the shaft back and forth to disengage.
4. Rotate to the desired position
5. Actuator will reengage when the knob is released and power is applied.
6. Do not turn beyond normal travel.

Section 2.0 Installation

2.1 Factory Installation

For applications requiring the EASC card, generally this card is factory-installed into the actuator for Bran+Luebbe. For part numbers, refer to the table in section 7.1, on page 22.

2.2 Mounting Procedure if not factory-installed

A kit with all necessary components for the EASC card is available from Bran+Luebbe. For part numbers, refer to table in section 7.2 on page 22.

Install the mounting bracket in the actuator. Wire the card as shown in the connection diagram (Figure 3, page 9 and Figure 12-15 on pages 29 and 30). Calibrate the unit following the instructions in section 3.2.6, page 12.

If the actuator is to be mounted on a pump assembly, ensure the pump is mechanically zeroed and the actuator is zeroed before assembly. Ensure the limit switches are properly set to limit travel within the metering pump range. If the actuator is already properly installed on the pump, and the limit switches properly set, no special steps are needed for aligning the actuator and pump.

2.3 Mounting Procedure if replacing APC cards

A kit with all necessary components for the EASC card is available from Bran+Luebbe. For part numbers, refer to table in section 7.2 on page 22.

Remove APC card and bracket. Install the EASC mounting bracket and card. Wire the card as shown in connection diagram (Figure 3 on page 9) and reconnection table (page 23) as well as the reference diagrams on page 29. Calibrate unit following the instructions in section 3.2.6, page 12.

If the actuator is to be mounted on a pump assembly, ensure the pump is mechanically zeroed and the actuator is zeroed before assembly. Ensure the limit switches are properly set to limit travel within the metering pump capability. If the actuator is already properly installed on the pump, and the limit switches properly set, no special steps are needed for aligning the actuator and pump.

2.4 Connection Diagram

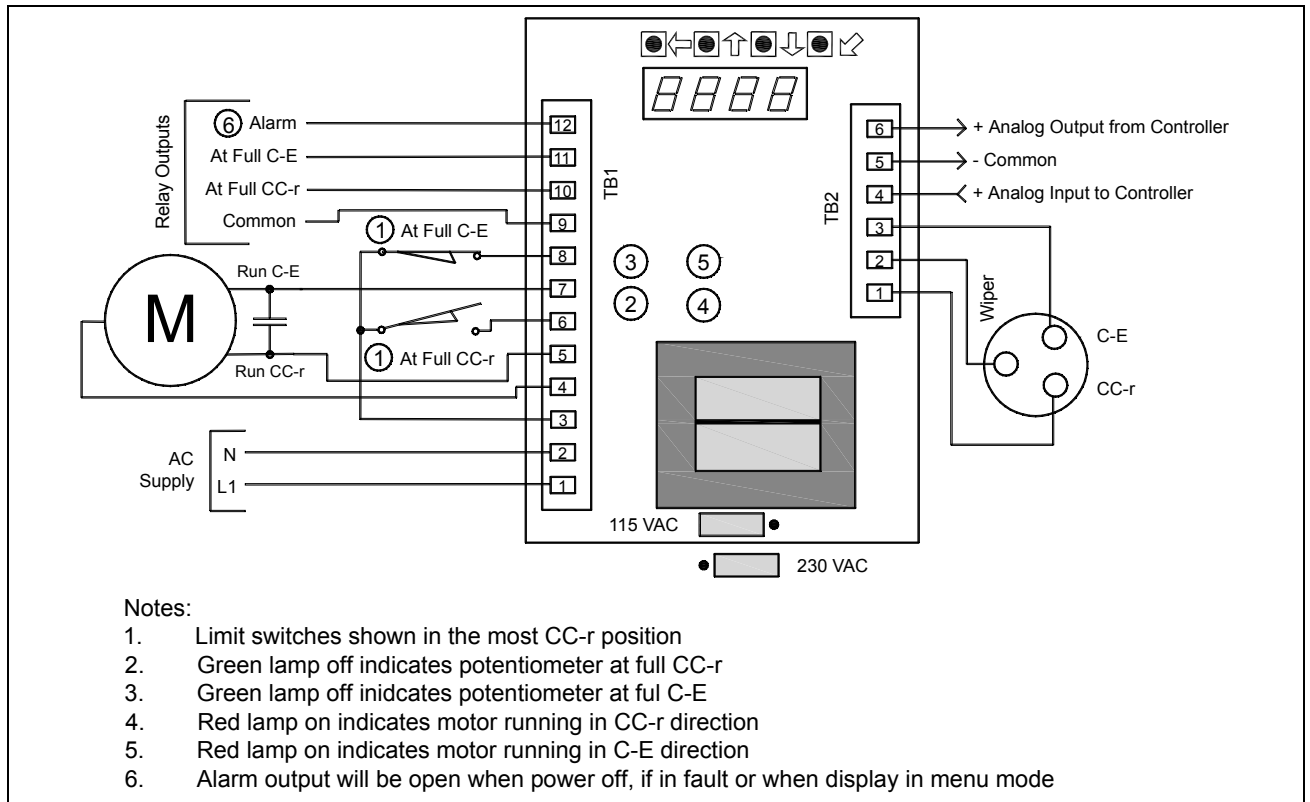

Figure 3 - Connection Details

Note: An electronic fuse - 5 Amp (250V) time delay fuse - is mounted on the card. Replace with Bussmann GDC-5A, Littlefuse 218005 or equivalent.

2.5 Analog Connections

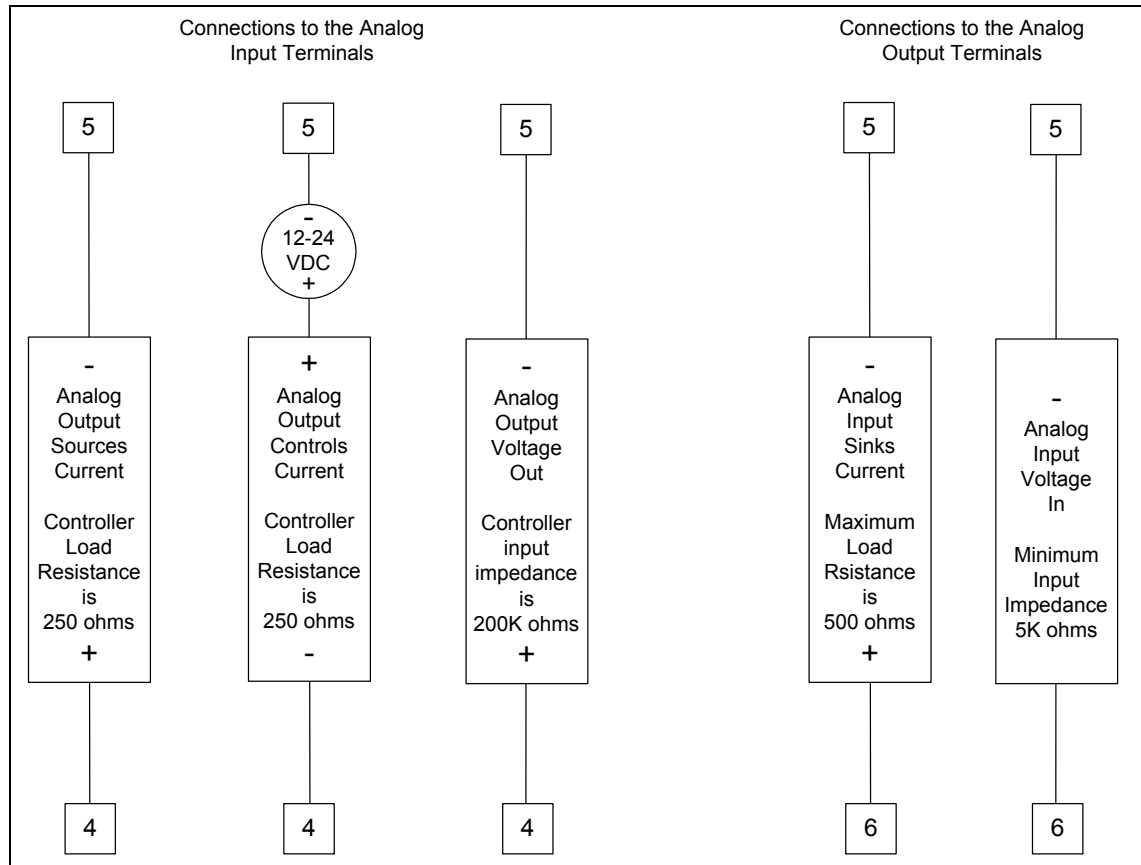

Figure 4 - Analog Connections

Section 3.0 Card Setup Procedure

3.1 General

- 3.1.1 The following instructions assume that the EASC board is installed in the actuator. If the EASC card was field-installed, ensure all safety, installation and startup instructions outlined in the appropriate RCS and ANDCO installation and instruction manuals have been performed. Be certain the actuator is in proper operating condition before attempting to calibrate the EASC board. Except for the procedures described in section 3.2.5 and 3.2.6, the actuator will not move during setup.
- 3.1.2 The use of the Basic Set Up instructions is suitable for:
- Input signal requirements of 4-20 mA-DC, 1-5 V DC, 0-10 V DC or 2-10 V DC
 - Output signal requirements of 4-20 mA-DC, 1-5 V DC, 0-10 V DC or 2-10 V DC
 - Loss of input signal: actuator does not move, fails in last place. For a setting of **ZERO** input signal, the system fails to minimum signal position.
- For all other options, see section 3.4 and 3.5.
- 3.1.3 The terms “clockwise” and “counterclockwise” refer to the direction of rotation of the actuator output shaft as viewed from the top of the actuator. The EASC must be wired as shown in Figure 3 on page 9. Refer to Figure 3 for status lamp descriptions. Output rotation is changed using instructions in 3.2.4 on page 12.

Key Functions: The indicators are located to the right of the buttons located at the top of the card.





	Go BACK one menu level and do not save value
	Move UP through menus or increase a value
	Move DOWN through menus or decrease value
	SELECT a menu item or save value

Figure 5 - Key Functions for Buttons on Card

3.2 Basic Set Up

3.2.1 Order of display

Order	Instruction	Description
1	in	Configuration information – Analog input
2	io	Non-Standard Configuration information
3	Cal	Automatic Calibration process
4	Pot	Set up information – Feedback pot
5	rotn	Configuration information – Output shaft rotation
6	oUt	Configuration information – Analog output

3.2.2 Setting the analog input type:

1. Use the \uparrow or \downarrow keys until **in** is displayed, then press the **SELECT** key.
2. Press the \uparrow or \downarrow key until the type of input signal required, **1-5 V DC**, **0-10 V DC**, **2-10 V DC**, **4-20 mA-DC** is displayed.
3. Press the **SELECT** key to save the selection.

3.2.3 Setting the analog output type:

1. Use the \uparrow or \downarrow keys until **oUt** is displayed, then press the **SELECT** key.
2. Press the \uparrow or \downarrow key until the type of output signal required, **1-5 V DC**, **0-10 V DC**, **2-10 V DC**, **4-20 mA-DC** is displayed.
3. Press the **SELECT** key to save the selection.

3.2.4 Selecting output shaft rotation:

1. Press the \uparrow or \downarrow key until **rotn** is displayed, then press the **SELECT** key.
2. Press the \uparrow or \downarrow to select the direction of travel required to move the actuator towards the maximum signal position, **CC-r** (counterclockwise for rotary actuators) or **C-E** (clockwise for rotary actuators). See Figure 6 below for gear types and directional information.
3. Press the **SELECT** key to save the selection.

Direction for maximum flow	Gear Pump Type
CC-R (counterclockwise for increased flow)	P
C-E (Clockwise for increased flow)	K, J, D, DS, CS

*Figure 6 - Pump Rotation for Increased Flow***3.2.5 Positioning the potentiometer shaft:**

1. Press the \uparrow or \downarrow key until **Pot** is displayed, then press the **SELECT** key.
2. The display will change to show the actual potentiometer value in internal divisions (0-1023) and the \uparrow or \downarrow keys will now operate the actuator motor.
3. Run the actuator to approximately 50% of travel. Loosen the set- screws retaining the potentiometer shaft. Rotate the shaft until the display reads approximately 510 divisions (50% of potentiometer span). Retighten the set-screws.
4. To verify the potentiometer and limit switch settings, press the \uparrow key to move the actuator electrically. The value displayed on the LED array should increase towards the maximum of 1023 divisions. When the limit switch stops the actuator, check that the switch setting is correct for the required travel. The displayed value will typically be 975 divisions or less, but must not exceed 1000 divisions.
5. Now press the \downarrow key to move the actuator in the opposite direction of travel. The value displayed should decrease in value towards the minimum value of **0**. The displayed value will typically be 50 divisions or more, but must not be less than 20 divisions. The difference between the end of travel values must be at least 500 divisions.
6. Press the **SELECT** key to exit potentiometer setup.

3.2.6 Calibrating the controller:

1. Press the \uparrow or \downarrow key until **Cal** is displayed, then press the **SELECT** key.
2. Press the \uparrow or \downarrow key until **YES** is displayed, then press the **SELECT** key.
3. The automatic calibration sequence will now begin. The display will indicate the calibration steps, 1 through 11, being performed. Should the calibration sequence fail, the display will indicate **CF X**, where **X** is the number of the calibration step that failed. No calibration values are saved unless the calibration sequence completes normally. When calibration is complete, the display will again show **Cal**.

3.2.7 Exiting setup mode:

Press the \leftarrow key until the display shows actual actuator position in increments of 0-100% and the actuator begins to follow the input command signal.

3.3 Reloading Factory Default Settings

1. Disconnect the power source from the actuator.
2. Press and hold the **SELECT** key.
3. Restore the power supply to the actuator.
4. The display will read: **Fact**, then **done**.
5. Release the **Select** key.

3.4 Setting non-Standard Input/Output Ranges

To select a nonstandard input/output range you will require a process loop calibrator or a multimeter and the actual process signal source. Connect the process calibrator or multimeter to the analog input and output terminals. See Figure 3 on page 9 for connection details. The actuator will not move during this procedure.

3.4.1 Setting a nonstandard analog input:

1. Select the voltage or current input range that most closely matches your nonstandard configuration using instructions in section 3.2.2 on page 11.
2. Use the \uparrow or \downarrow keys until **io** is displayed, then press the **SELECT** key.
3. Set the process calibrator to the lowest input value.
4. Use the \uparrow or \downarrow keys until **ioFt** is displayed, then press the **SELECT** key.
5. Use the \uparrow or \downarrow keys to set the controller display to **0**.
6. Press the **SELECT** key to save the selection.
7. Set the process calibrator to highest input value.
8. Use the \uparrow or \downarrow keys until **iSPn** is displayed, then press the **SELECT** key.
9. Use the \uparrow or \downarrow keys to set the controller display to **100**, or to full scale if the full-scale value has been modified from **100**.
10. Press the **SELECT** key to save the selection.
11. Press the \leftarrow key until the display shows actual actuator position in increments of 0-100% and the actuator begins to follow the input command signal.

3.4.2 Setting a nonstandard analog output:

1. Select the voltage or current output range that most closely matches your nonstandard configuration using instructions in 3.2.3, page 11.
2. Use the \uparrow or \downarrow keys until **io** is displayed, then press the **SELECT** key.
3. Use the \uparrow or \downarrow keys until **ooFt** is displayed, then press the **SELECT** key.
4. Use the \uparrow or \downarrow keys to set the output signal lowest value as displayed on the process calibrator or multi-meter. The controller will automatically set the output to the lowest value during this step.
5. Press the **SELECT** key to save the selection.
6. Use the \uparrow or \downarrow keys until **oSPn** is displayed, then press the **SELECT** key.
7. Use the \uparrow or \downarrow keys to set the output signal highest value as displayed on the calibrator or multi-meter. The controller will automatically set the output to the highest value during this step.
8. Press the **SELECT** key to save the selection.
9. Press the \leftarrow key until the display shows actual actuator position in increments of 0-100% and the actuator begins to follow the input command signal.

3.5 Selecting an Alternate Fail Position on Loss of Command Signal

The controller can sense the loss of the analog input signal for configurations that have an input signal of at least 2% of full scale above zero input. Two settings are available, loss of signal threshold and position on loss of signal. The **EASC** offers four failure modes to control the movement of the actuator in the event of a command signal loss:

- Fail in last position: no actuator movement upon loss of signal. This is the factory default setting.
- Fail to the full clockwise position
- Fail to the full counterclockwise position
- Fail to a preset position

NOTE: For a setting of **ZERO** input signal, the system fails to minimum signal position.

3.5.1 Setting the Fail Safe Position:

1. Use the \uparrow or \downarrow keys until **io** is displayed, then press the **SELECT** key.
2. Use the \uparrow or \downarrow keys until **FSPn** is displayed, then press the **SELECT** key.
3. Use the \uparrow or \downarrow keys to set the fail-safe position to the required location. Setting the fail-safe position to greater than 100, or full scale, will enable fail in last position. The fail safe system will be disabled if the fail safe position is set to zero..
4. Press the **SELECT** key to save the selection.

3.5.2 Setting the Fail-Safe Loss of Signal Threshold:

1. Use the \uparrow or \downarrow keys until **io** is displayed, then press the **SELECT** key.
2. Use the \uparrow or \downarrow keys until **FStH** is displayed, then press the **SELECT** key.
3. Use the \uparrow or \downarrow keys to set the input threshold in percent, or units of full scale, where the fail-safe function will be activated. The fail-safe function will be activated whenever the input signal falls below the threshold setting. Hysteresis of 1% is automatically provided on the fail-safe threshold.
4. Press the **SELECT** key to save the selection.

Section 4.0 Automatic Calibration

The controller automatically determines the best operating parameters for the attached actuator. Instructions for starting a calibration are in section 3.2.6 on page 12. The active calibration step is shown on the display throughout the calibration cycle. Should the controller be unable to complete the calibration cycle, the step where the cycle halted will be displayed as **CFXX**, with **XX** being the step number. The following are the steps performed during a calibration:

1. Capture the current detection system input offset, then start a two-second move towards the full signal limit switch.
2. When the two-second timer expires, start a move towards the minimum signal limit switch.
3. Move towards the minimum signal limit switch, then when motion ceases, start a two-second timer.
4. When the two-second timer expires, capture the potentiometer zero offset, then start a move to the full signal limit switch.
5. Move towards the full signal limit switch, then when motion ceases, capture the potentiometer span and actuator full movement time and setup a move to the 25% position.
6. Move towards the 25% position, then when the set point is achieved, stop movement and setup a two-second delay.
7. When the two-second timer expires, capture the move towards minimum setback value, then setup a move to the 75% position.
8. Move towards the 75% position, then when the set point is achieved, stop movement and setup a two-second delay.
9. When the two-second timer expires, capture the move towards maximum setback value, then determine if jogging is required; if yes, go to step 10; if no, save all of the parameters to nonvolatile memory and exit calibration.
10. Run the motor for jog on time, alternating jog direction with each jog. When the jog is finished, set up the jog wait timer.
11. When the jog wait timer expires, adjust the jog timing (if required). If jog timing is adjusted, go to step 10; otherwise if 3 jogs have completed without adjustment, save jog on time, maximum jog on time and minimum jog on time, then save all of the parameters to nonvolatile memory and exit calibration.

The calibration system only saves the calculated parameters upon completion of a calibration cycle. Terminating calibration will restore all of the parameters to the pre-calibration values.

Section 5.0 Card Settings

5.1 Basic

Items in the Basic Setup Menu are adjusted using the instructions contained in sections 3.2.2 through 3.2.5 on pages 11-12; section 3.4 on page 13; and section 3.5 on page 14.

Group	Item	Description	Setting
<i>in</i>	0-10	Sets analog input to 0-10 V DC range	
	2-10	Sets analog input to 2-10 V DC range	
	1-5	Sets analog input to 1-5 V DC range	
	4-20	Sets analog input to 4-20 mA DC range	4-20 mA DC
<i>oUt</i>	0-10	Sets analog output to 0-10 V DC range	
	2-10	Sets analog output to 2-10 V DC range	
	1-5	Sets analog output to 1-5 V DC range	
	4-20	Sets analog output to 4-20 mA DC range	4-20 mA DC
<i>rotn</i>	CC	Maximum input signal moves actuator shaft to fully counter-clockwise or retracted.	CC (For 20 turn actuators)
	C	Maximum input signal moves actuator to fully clockwise/extended	C (For 30/ 60 turn actuators)
<i>Pot</i>		Pressing \uparrow key moves actuator to increase potentiometer value. Pressing \downarrow key moves actuator to decrease potentiometer value. Display shows actual potentiometer value from 10 - 1023	Normally used only if verifying or setting up potentiometer range
<i>CAL</i>	no	Used to initiate a self-calibration. See section 3.2.6 on page 12.	
<i>io</i>	ioft	Analog input offset, display shows input value in units of full scale	Offset set for 4 mA = 0%
	iSPn	Analog input span, display shows input value in units of full scale	Span set for 20 mA = 100%
	ooFt	Analog output offset, display shows output voltage in internal units	Offset set for 0% = 4 mA
	oSPn	Analog output span, display shows output voltage in internal units	Span set for 100% = 20 mA
	FStH	Fail-safe threshold in units of full scale	1%
	FSPn	Fail-safe position in units of full scale	101% (Do not move on input signal fault)

5.2 Advanced

The advanced setup menu allows access to many configuration parameters that are set automatically by the calibration system. These parameters should be adjusted only if the automatically set values are not suitable for your application. Erratic operation can occur if these values are adjusted; use caution when adjusting calibration set parameters.

Operation of the keyboard and display during Advanced Setup is the same as for Basic Setup. To enter the advanced setup menu:

1. Use the \uparrow or \downarrow keys until **in** is displayed.
2. Press and hold the **SELECT** key for 10 seconds.
3. The advanced menu is entered when the display shows **ACC**.

Group	Item	Description	Setting
ACC		Controller accuracy menu	
	SACC	Seek to position accuracy in units of full scale. Adjust this parameter to stop actuator hunting. Increasing the value of this parameter will decrease the position accuracy of the actuator.	1
	FSCL	Full scale value. Increasing this value will divide the input range into smaller increments. This value impacts many other parameters, which will have to be reset should this value be changed. Increase this parameter only if the underlying mechanical system can provide accuracy in excess of 1%.	100
	FCLS	Force to zero value. Inputs less than this value in units of full scale will cause the actuator to move to the lowest signal limit switch regardless of the actuator's potentiometer input value. This parameter insures the actuator moves to the minimum signal limit switch when the input signal nears minimum.	2
	FoPn	Force to full scale value. Inputs greater than this value in units of full scale will cause the actuator to move to the maximum signal limit switch regardless of the actuator's potentiometer input value. This parameter insures the actuator moves to the maximum signal limit switch when the input signal nears maximum.	98
JoG		Jogging system menu	
	Jon	Jog on time in 8.33 ms (for 60 Hz) or 10 ms (for 50 Hz) increments. Set automatically by the calibration system. This parameter is continuously adjusted during the normal operation within the range set by hion and Loon if jogging is enabled. The calibration system determines if jogging is required to achieve the SACC accuracy value.	20
	JoFF	Jog off or waiting time in 0.1-second increments. The jogging system is disabled by setting this value to zero. The calibration system determines if jogging is required and sets this value to 10 automatically.	10
	hion	Maximum jog on time in 8.33 ms (for 60 Hz) or 10 ms (for 50 Hz) increments. Set automatically by the calibration system. Determines the upper range of jog on times.	40
	Loon	Minimum jog on time in 8.33 ms (for 60 Hz) or 10 ms (for 50 Hz) increments. Set automatically by the calibration system. Determines the lower range of jog on times.	1

Group	Item	Description	Setting
Prot		Controller protection menu	
	tFLt	Movement fault timeout time in 1-second increments. This timer is started each time a movement begins. If the timer expires, the motor is stopped and will not restart until the direction of movement is changed. Set automatically by the calibration system.	60
	trnd	Motor turnaround time in 0.1-second increments. This timer imposes a delay whenever the motor changes direction.	10
	hCUR	Maximum motor running current in 0.01A increments. Currents above this value will start the over current fault timer. When the over current fault timer expires the motor is shut off and will not restart until the direction of rotation is changed. The optional current sensor is required for this feature.	200
	tCUR	Motor over-current time to fault in seconds. Set to zero, disable the current monitoring feature. The optional current sensor is required for this feature.	0
	Coft	Current detector offset in internal units. Set automatically by the calibration system	0
Group	Item	Description	Setting
	CSPn	Current detector span in internal units. Adjust this parameter until the displayed value matches the actual motor current measured with an external meter.	255
LPoL		Limit switch polarity menu	
	oPoL	Selects the polarity of the maximum input signal limit switch relay output contact, n.o. = normally open, n.c. = normally closed,	n.o.
	CPoL	Selects the polarity of the minimum input signal limit switch relay output contact, n.o. = normally open, n.c. = normally closed	n.o.

Section 6.0 Available Controller Menus

6.1 Basic

Items in the Basic Setup Menu are adjusted using the instructions contained in section 3.2.2 through 3.2.5 on pages 11-12; section 3.4 on page 13; and section 3.5 on page 14.

Group	Item	Description	Default Setting
<i>in</i>	0-10	Sets analog input to 0-10 V DC range	
	2-10	Sets analog input to 2-10 V DC range	
	1-5	Sets analog input to 1-5 V DC range	1-5 V DC
	4-20	Sets analog input to 4-20 mA DC range	
<i>oUt</i>	0-10	Sets analog output to 0-10 V DC range	
	2-10	Sets analog output to 2-10 V DC range	
	1-5	Sets analog output to 1-5 V DC range	1-5 V DC
	4-20	Sets analog output to 4-20 mA DC range	
<i>rotn</i>	CC	Maximum input signal - actuator to fully counter-clockwise/retracted.	CC
	C	Maximum input signal - actuator shaft to full clockwise/extended	
<i>Pot</i>		Pressing \uparrow key moves actuator to increase potentiometer value. Pressing \downarrow key moves actuator to decrease potentiometer value. Display shows actual potentiometer value from 10 - 1023	
<i>CAL</i>	no	Used to initiate a self-calibration. See section 3.2.6 on page 12.	
<i>io</i>	ioft	Analog input offset, display shows input value in units of full scale	Offset set for 1 V DC = 0%
	iSPn	Analog input span, display shows input value in units of full scale	Span set for 5 V DC = 100%
	ooFt	Analog output offset, display shows output voltage in internal units	Offset set for 0% = 1 V DC
	oSPn	Analog output span, display shows output voltage in internal units	Span set for 100% = 5 V DC
	FStH	Fail-safe threshold in units of full scale	1%
	FSPn	Fail-safe position in units of full scale	101% (Do not move on input signal fault)

6.2 Advanced

The advanced setup menu allows access to many configuration parameters that are set automatically by the calibration system. These parameters should be adjusted only if the automatically set values are not suitable for your application. Erratic operation can occur if these values are adjusted, use caution when adjusting calibration set parameters.

Operation of the keyboard and display during Advanced Setup is the same as for Basic Setup. To enter the advanced setup menu:

1. Use the \uparrow or \downarrow keys until **in** is displayed.
2. Press and hold the **SELECT** key for 10 seconds.
3. The advanced menu is entered when the display shows **ACC**.

Group	Item	Description	Default Setting	Range
ACC		Controller accuracy menu		
	SACC	Seek to position accuracy in units of full scale. Adjust this parameter to stop actuator hunting. Increasing the value of this parameter will decrease the position accuracy of the actuator.	1	0-1023
	FSCL	Full scale value. Increasing this value will divide the input range into smaller increments. This value impacts many other parameters, which will have to be reset should this value be changed. Increase this parameter only if the underlying mechanical system can provide accuracy in excess of 1%.	100	0-1023
	FCLS	Force to zero value. Inputs less than this value in units of full scale will cause the actuator to move to the lowest signal limit switch regardless of the actuator's potentiometer input value. This parameter insures the actuator moves to the minimum signal limit switch when the input signal nears minimum.	2	0-4
	FoPn	Force to full scale value. Inputs greater than this value in units of full scale will cause the actuator to move to the maximum signal limit switch regardless of the actuator's potentiometer input value. This parameter insures the actuator moves to the maximum signal limit switch when the input signal nears maximum.	98	up to -4 from full scale
JoG		Jogging system menu		
	Jon	Jog on time in 8.33 ms (for 60 Hz) or 10 ms (for 50 Hz) increments. Set automatically by the calibration system. This parameter is continuously adjusted during the normal operation within the range set by hion and Loon if jogging is enabled. The calibration system determines if jogging is required to achieve the SACC accuracy value.	20	0-255
	JoFF	Jog off or waiting time in 0.1-second increments. The jogging system is disabled by setting this value to zero. The calibration system determines if jogging is required and sets this value to 10 automatically.	10	0-255
	hion	Maximum jog on time in 8.33 ms (for 60 Hz) or 10 ms (for 50 Hz) increments. Set automatically by the calibration system. Determines the upper range of jog on times.	40	0-255

Group	Item	Description	Default Setting	Range
	Loon	Minimum jog on time in 8.33 ms (for 60 Hz) or 10 ms (for 50 Hz) increments. Set automatically by the calibration system. Determines the lower range of jog on times.	1	0-255
Prot		Controller protection menu		
	tFLt	Movement fault timeout time in 1-second increments. This timer is started each time a movement begins. If the timer expires, the motor is stopped and will not restart until the direction of movement is changed. Set automatically by the calibration system.	60	0-255
	trnd	Motor turnaround time in 0.1-second increments. This timer imposes a delay whenever the motor changes direction.	10	0-255
	hCUr	Maximum motor running current in 0.01A increments. Currents above this value will start the over current fault timer. When the over current fault timer expires the motor is shut off and will not restart until the direction of rotation is changed. The optional current sensor is required for this feature.	200	0-1023
	tCUr	Motor over-current time to fault in seconds. Set to zero, disable the current monitoring feature. The optional current sensor is required for this feature.	0	0-255
	Coft	Current detector offset in internal units. Set automatically by the calibration system	0	0-1022
	CSPn	Current detector span in internal units. Adjust this parameter until the displayed value matches the actual motor current measured with an external meter.	255	0-1023
LPoL		Limit switch polarity menu		
	oPoL	Selects the polarity of the maximum input signal limit switch relay output contact, n.o. = normally open, n.c. = normally closed,	n.o.	n.o. / n.c.
	CPoL	Selects the polarity of the minimum input signal limit switch relay output contact, n.o. = normally open, n.c. = normally closed	n.o.	n.o. / n.c.

Section 7.0 Parts Available

7.1 Actuators with EASC Cards installed

Component	Part Number
20 turn actuator in NEMA 4 enclosure (008868B), with EASC Card	1441002B
30 turn actuator in NEMA 4 enclosure (008868B-1), with EASC Card	1441002B-1
60 turn actuator) in NEMA 4 enclosure (008872B), with EASC Card	1441003B
20 turn actuator in NEMA 7 enclosure (008870B), with EASC Card	1441006B
30 turn actuator in NEMA 7 enclosure (008870B-1), with EASC Card	1441006B-1
60 turn actuator) in NEMA 7 enclosure (008874B), with EASC Card	1441005B

Figure 7 - Bran+Luebbe Part Numbers - Actuators

7.2 EASC Card Kits and Associated Parts

Component	Part Number
SCC10 Kit (EASC Card with bracket for field installation)	1441001B
Littlefuse Slo Blo Fuse 218005 (replacement for card mounted fuse)	1441000B

Figure 8 - Bran+Luebbe Part Numbers - Kits and Associated Parts

Section 8.0 Wiring terminal changes for converting APC to EASC Installation

			APC Card	EASC From RCS	
Field Wiring	Analog Output (Act. location)	+	13	TB2 - 6	
		-	14	TB2 - 5	
	Analog Input (Positioning Signal)	+	7	TB2 - 4	
		-	8	TB2 - 5	
	Power 115 V 60 HZ	+ or Line	1	TB1 - 1	
		- or Neutral	4	TB1 - 2	
	Alarm	Output		TB1 - 12	
		Common		TB1 - 9	
	At Full C-E	Output		TB1 - 10	
		Common		TB1 - 9	
	At Full CC-r	Output		TB1 - 11	
		Common		TB1 - 9	
	To Actuator Wiring	Pot. Feedback	C-E (FB HI)	10	TB2 - 3
CC-r (FB LOW)			12	TB2 - 1	
Wiper			11	TB2 - 2	
Motor		Run C-E	3	TB1 - 7	
		Run CC-r	2	TB1 - 5	
		Neutral	4	TB1 - 4	
Limit Switches		Full C-E		TB1 - 8	
		Full CC-r		TB1 - 6	
		Common		TB1 - 3	
Meter Output		+	9		
		-	6		

Section 9.0 Quick Set Up Information

9.1 Connection Diagram

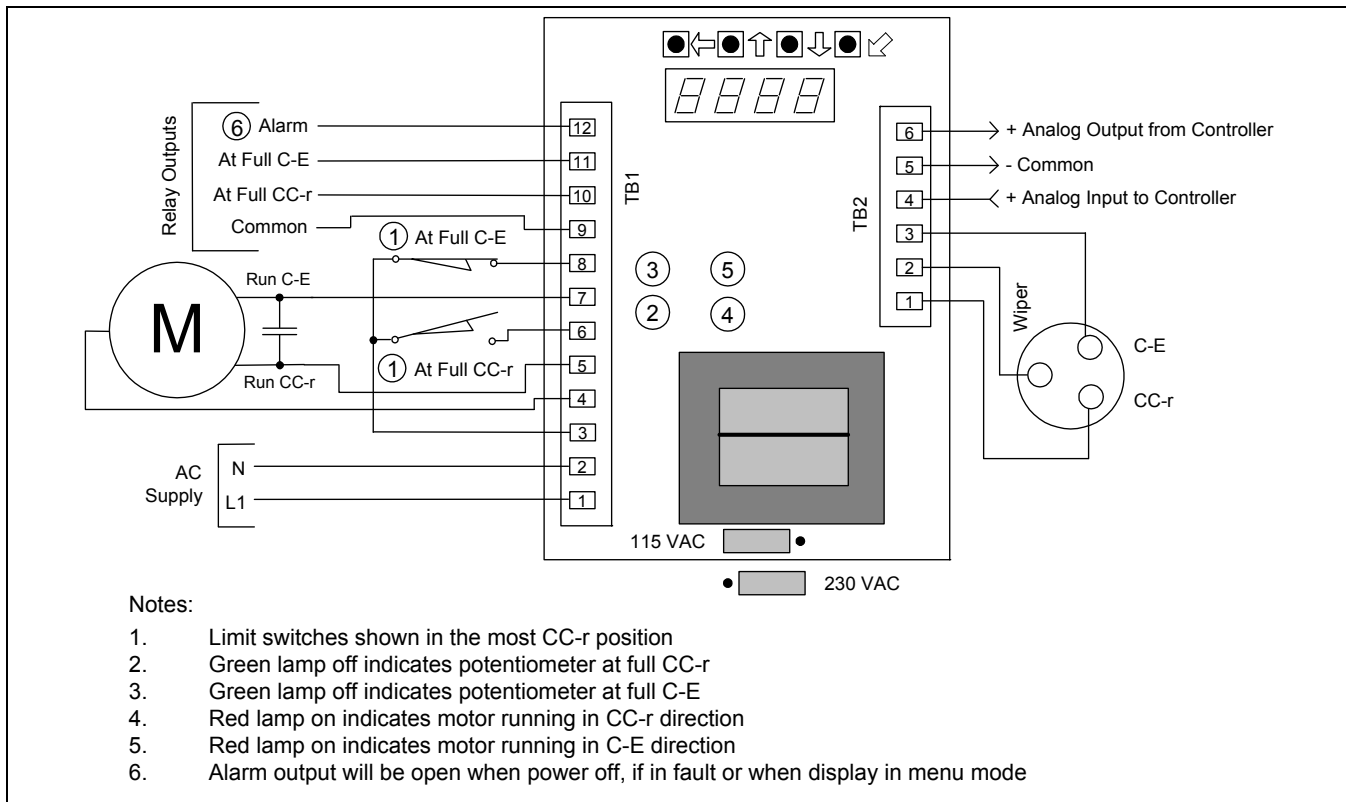

Figure 9 - Quick Calibrate Connection Details

Note: An electronic fuse - 5 Amp (250V) time delay fuse - is mounted on the card. Replace with Bussmann GDC-5A, Littelfuse 218005 or equivalent.

9.2 General information for Quick Set Up

1. The following instructions assume that the EASC board is installed in the actuator and all safety, installation and startup instructions outlined in the appropriate installation and instruction manuals have been carried out. Be certain the actuator is in proper operating condition before attempting to calibrate the **EASC** board. Except for items 9.3.5 and 9.3.6 on page 26, the actuator will not move during setup.
2. The Quick Setup instructions are suitable for:
 - Input signal requirements of 4-20 mA-DC, 1-5 V DC, 0-10 V DC or 2-10 V DC
 - Output signal requirements of 4-20 mA-DC, 1-5 V DC, 0-10 V DC or 2-10 V DC
 - Loss of input signal: actuator does not move, fails in last place. For a setting of **ZERO** input signal, the system fails to minimum signal position.

For all other options, refer to Section 3.0.
3. The terms “clockwise” and “counterclockwise” refer to the direction of rotation of the actuator output shaft, as viewed from the top of the actuator. The **EASC** must be wired as shown in Figure 9. Refer to Figure 9 for status lamp descriptions. Output rotation is changed using the instructions in section 9.3.4, page 25.

Key Functions: The indicators are located to the right of the buttons located at the top of the card.





	Go BACK one menu level and do not save value
	Move UP through menus or increase a value
	Move DOWN through menus or decrease value
	SELECT a menu item or save value

Figure 10 - Quick Set Up Key Functions for Buttons on Card

9.3 Quick Set Up

9.3.1 Order of display

Order	Instruction	Description
1	in	Configuration information – Analog input
2	io	Non-Standard Configuration information
3	Cal	Automatic Calibration process
4	Pot	Set up information – Feedback pot
5	rotn	Configuration information – Output shaft rotation
6	oUt	Configuration information – Analog output

9.3.2 Setting the analog input type:

1. Use the \uparrow or \downarrow keys until **in** is displayed, then press the **SELECT** key.
2. Press the \uparrow or \downarrow key until the type of input signal required, **1-5 V DC**, **0-10 V DC**, **2-10 V DC**, **4-20 mA-DC** is displayed.
3. Press the **SELECT** key to save the selection.

9.3.3 Setting the analog output type:

1. Use the \uparrow or \downarrow keys until **oUt** is displayed, then press the **SELECT** key.
2. Press the \uparrow or \downarrow key until the type of output signal required, **1-5 V DC**, **0-10 V DC**, **2-10 V DC**, **4-20 mA-DC** is displayed.
3. Press the **SELECT** key to save the selection.

9.3.4 Selecting output shaft rotation:

1. Press the \uparrow or \downarrow key until **rotn** is displayed, then press the **SELECT** key.
2. Press the \uparrow or \downarrow to select the direction of travel required to move the actuator towards the maximum signal position, **CC-r** (counterclockwise for rotary actuators) or **C-E** (clockwise for rotary actuators). See Figure 11 below for gear types and directional information.
3. Press the **SELECT** key to save the selection.

Direction for maximum flow	Gear Pump Type
CC-R (counterclockwise for increased flow)	P
C-E (Clockwise for increased flow)	K, J, D, DS, CS

Figure 11 – Quick Set Up Pump Rotation for Increased Flow

9.3.5 Positioning the potentiometer shaft:

1. Press the \uparrow or \downarrow key until **Pot** is displayed, then press the **SELECT** key.
2. The display will change to show the actual potentiometer value in internal divisions (0-1023) and the \uparrow or \downarrow keys will now operate the actuator motor.
3. Run the actuator to approximately 50% of travel. Loosen the set- screws retaining the potentiometer shaft. Rotate the shaft until the display reads approximately 510 divisions (50% of potentiometer span). Retighten the set-screws.
4. To verify the potentiometer and limit switch settings, press the \uparrow key to move the actuator electrically. The value displayed on the LED array should increase towards the maximum of 1023 divisions. When the limit switch stops the actuator, check that the switch setting is correct for the required travel. The displayed value will typically be 975 divisions or less, but must not exceed 1000 divisions.
5. Now press the \downarrow key to move the actuator in the opposite direction of travel. The value displayed should decrease in value towards the minimum value of **0**. The displayed value will typically be 50 divisions or more, but must not be less than 20 divisions. The difference between the end of travel values must be at least 500 divisions.
6. Press the **SELECT** key to exit potentiometer setup.

9.3.6 Calibrating the controller:

1. Press the \uparrow or \downarrow key until **Cal** is displayed, then press the **SELECT** key.
2. Press the \uparrow or \downarrow key until **YES** is displayed, then press the **SELECT** key.
3. The automatic calibration sequence will now begin. The display will indicate the calibration steps, 1 though 11, being performed. Should the calibration sequence fail, the display will indicate **CF X**, where **X** is the number of the calibration step that failed. No calibration values are saved unless the calibration sequence completes normally. When calibration is complete, the display will again show **Cal**.

9.3.7 Exiting setup mode:

Press the \leftarrow key until the display shows actual actuator position in increments of 0-100% and the actuator begins to follow the input command signal.

9.4 Reloading Factory Default Settings

1. Disconnect the power source from the actuator.
2. Press and hold the **SELECT** key.
3. Restore the power supply to the actuator.
4. The display will read: **Fact**, then **done**.
5. Release the **Select** key.

9.5 Automatic Calibration

The controller automatically determines the best operating parameters for the attached actuator. Instructions for starting a calibration are in section 9.3.6 on page 26. The active calibration step is shown on the display throughout the calibration cycle. Should the controller be unable to complete the calibration cycle, the step where the cycle halted will be displayed as **CFXX**, with **XX** being the step number. The following are the steps performed during a calibration:

1. Capture the current detection system input offset, then start a two second move towards the full signal limit switch.
2. When the two-second timer expires, start a move towards the minimum signal limit switch.
3. Move towards the minimum signal limit switch, then when motion ceases, start a two-second timer.
4. When the two-second timer expires, capture the potentiometer zero offset, then start a move to the full signal limit switch.
5. Move towards the full signal limit switch, then when motion ceases, capture the potentiometer span and actuator full movement time and setup a move to the 25% position.
6. Move towards the 25% position, then when the set point is achieved, stop movement and setup a two-second delay.
7. When the two-second timer expires, capture the move towards minimum setback value, then setup a move to the 75% position.
8. Move towards the 75% position, then when the set point is achieved, stop movement and setup a two-second delay.
9. When the two-second timer expires, capture the move towards maximum setback value, then determine if jogging is required; if yes go to step 10, if no save all of the parameters to nonvolatile memory and exit calibration.
10. Run the motor for jog on time, alternating jog direction with each jog; when the jog is finished, setup the jog wait timer.
11. When the jog wait timer expires, adjust the jog timing if required. If jog timing is adjusted go to step 10, otherwise if 3 jogs have completed without adjustment, save jog on time, maximum jog on time and minimum jog on time, then save all of the parameters to nonvolatile memory and exit calibration.

The calibration system only saves the calculated parameters upon completion of a calibration cycle. Terminating calibration will restore all of the parameters to the pre-calibration values.

9.6 Basic Card Settings

Group	Item	Description	Setting
<i>in</i>	0-10	Sets analog input to 0-10 V DC range	
	2-10	Sets analog input to 2-10 V DC range	
	1-5	Sets analog input to 1-5 V DC range	
	4-20	Sets analog input to 4-20 mA DC range	4-20 mA DC
<i>oUt</i>	0-10	Sets analog output to 0-10 V DC range	
	2-10	Sets analog output to 2-10 V DC range	
	1-5	Sets analog output to 1-5 V DC range	
	4-20	Sets analog output to 4-20 mA DC range	4-20 mA DC
<i>rotn</i>	CC	Maximum input signal - actuator to full counterclockwise/retracted.	CC (For 20 turn actuators)
	C	Maximum input signal moves actuator to fully clockwise/extended	C (For 30/ 60 turn actuators)
<i>Pot</i>		Pressing ↑ key moves actuator to increase potentiometer value. Pressing ↓ key moves actuator to decrease potentiometer value. Display shows actual potentiometer value from 10 - 1023	Normally only used if verifying or setting up potentiometer range
CAL	<i>no</i>	Used to initiate self-calibration. See Section 9.3.6 on page 26.	
<i>io</i>	<i>ioft</i>	Analog input offset, display shows input value in units of full scale	Offset set for 1 V DC = 0%
	<i>iSPn</i>	Analog input span, display shows input value in units of full scale	Span set for 5 V DC = 100%
	<i>ooFt</i>	Analog output offset, display shows output voltage in internal units	Offset set for 0% = 1 V DC
	<i>oSPn</i>	Analog output span, display shows output voltage in internal units	Span set for 100% = 5 V DC
	FSth	Fail-safe threshold in units of full scale	1%
	FSPn	Fail-safe position in units of full scale	101% (Do not move on input signal fault)

Section 10.0 Reference Diagrams

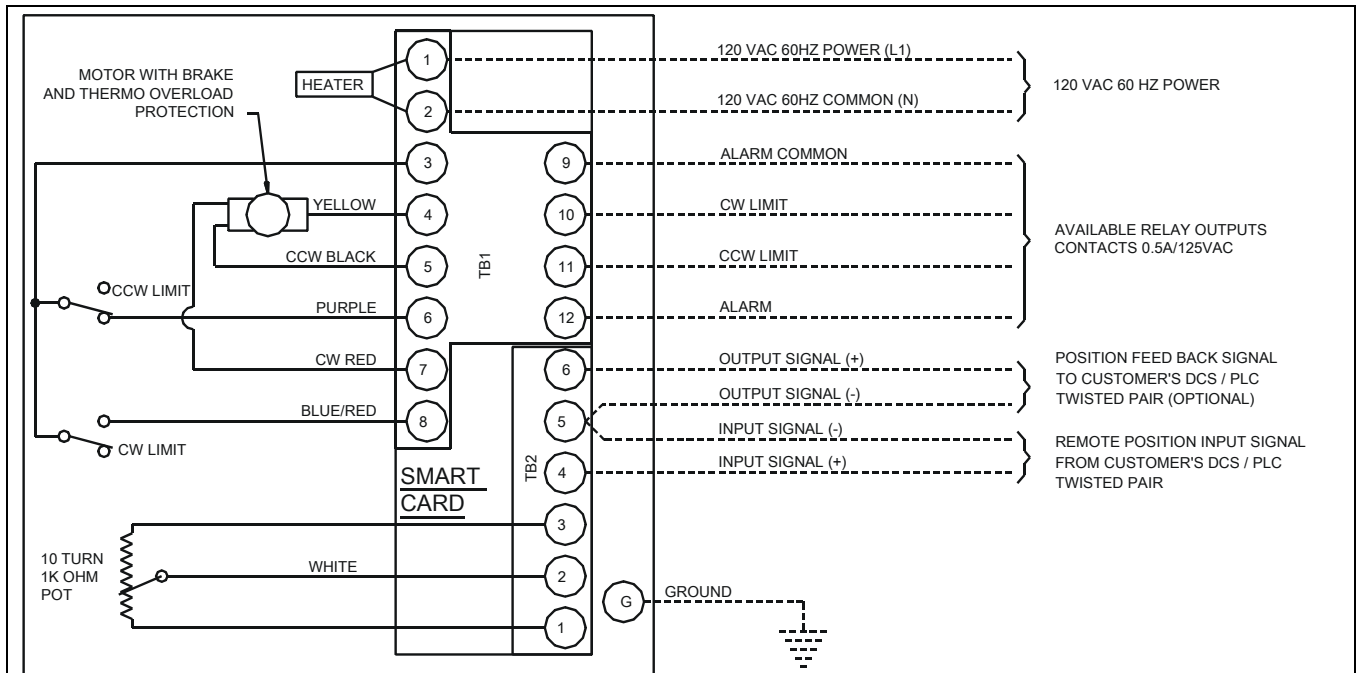

RCS ACTUATOR WITH INTERNAL SMART CARD

BLI-2211and12_3

NOTES:

1. POWER AND RELAY WIRING TO BE 600V PVC INSULATED WIRES.
2. ANALOG SIGNAL WIRES TO BE TWISTED PAIR.
3. INSTALLATION TO BE DONE ONLY BY A QUALIFIED ELECTRICIAN FOLLOWING ALL LOCAL CODES.
4. WIRING TYPICAL FOR 20MM, 30MM AND 60MM STROKE LENGTH PUMPS. SOME OF THE WIRE COLORS MAY CHANGE, FOLLOW TERMINAL NUMBERS.

Figure 12 – RCS Actuator with Internal Smart Card

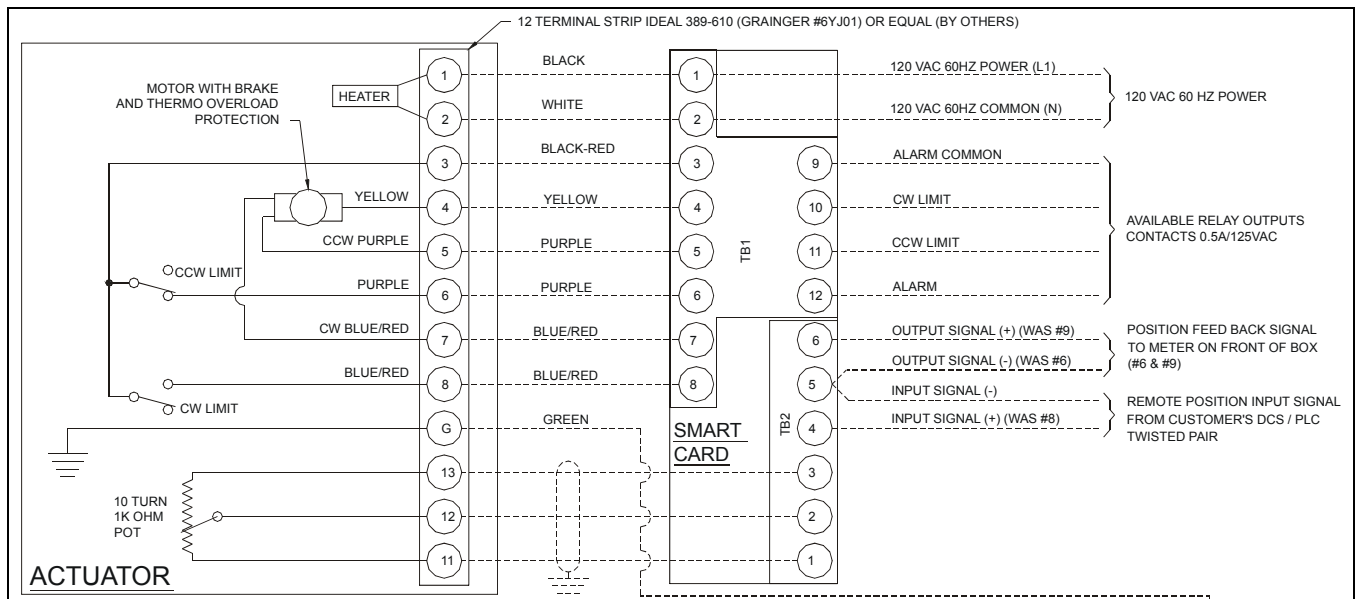

RCS ACTUATOR WITH REMOTE SMART CARD LOCATION

BLI-2211and12_6

NOTES:

1. POTENTIOMETER WIRING BETWEEN ACTUATOR AND REMOTE CONTROL CARD TO BE SHIELDED.
2. POWER AND RELAY WIRING TO BE 600V PVC INSULATED WIRES.
3. ANALOG SIGNAL WIRES TO BE TWISTED PAIR.
4. INSTALLATION TO BE DONE ONLY BY A QUALIFIED ELECTRICIAN FOLLOWING ALL LOCAL CODES.
5. WIRING TYPICAL FOR 20MM, 30MM AND 60MM STROKE LENGTH PUMPS. SOME OF THE WIRE COLORS MAY CHANGE; FOLLOW TERMINAL NUMBERS.

Figure 13 – RCS Actuator with Remote Smart Card Location

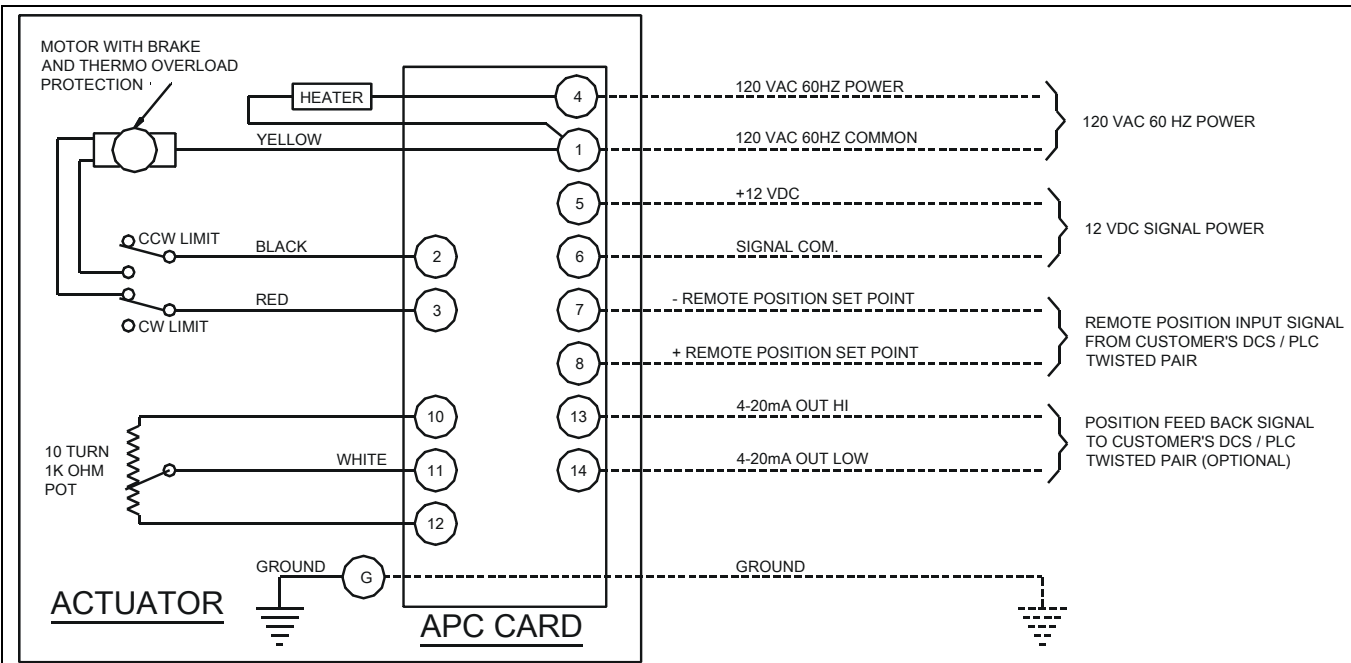

RCS ACTUATOR WITH INTERNAL APC CARD (Obsolete - for reference only)

BLI-2211and12_1

NOTES:

1. POWER AND RELAY WIRING TO BE 600V PVC INSULATED WIRES.
2. ANALOG SIGNAL WIRES TO BE TWISTED PAIR.
3. INSTALLATION TO BE DONE ONLY BY A QUALIFIED ELECTRICIAN FOLLOWING ALL LOCAL CODES.
4. WIRING TYPICAL FOR 20MM, 30MM AND 60MM STROKE LENGTH PUMPS. SOME OF THE WIRE COLORS MAY CHANGE, FOLLOW TERMINAL NUMBERS.

Figure 14 – RCS Actuator with Internal APC Card

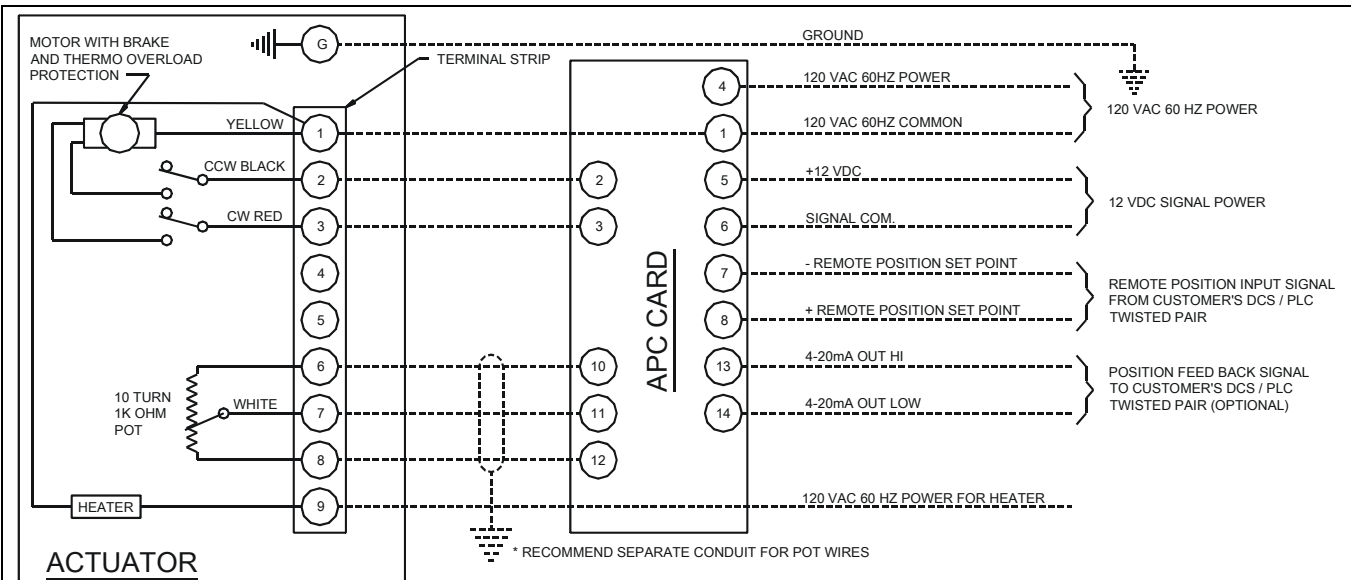

RCS ACTUATOR WITH REMOTE APC CARD LOCATION (Obsolete - for reference only)

BLI-2211and12_4

NOTES:

1. POTENTIOMETER WIRING BETWEEN ACTUATOR AND REMOTE CONTROL CARD TO BE SHIELDED.
2. POWER AND RELAY WIRING TO BE 600V PVC INSULATED WIRES.
3. ANALOG SIGNAL WIRES TO BE TWISTED PAIR.
4. INSTALLATION TO BE DONE ONLY BY A QUALIFIED ELECTRICIAN FOLLOWING ALL LOCAL CODES.
5. TERMINAL STRIP UPDATED MARCH 2006.
6. WIRING TYPICAL FOR 20MM, 30MM AND 60MM STROKE LENGTH PUMPS. SOME OF THE WIRE COLORS MAY CHANGE, FOLLOW TERMINAL NUMBERS.

Figure 15 – RCS Actuator with Remote APC Card Location

SPX[®]
PROCESS EQUIPMENT

Your local contact:



SPX Process Equipment
611 Sugar Creek Road
Delavan, WI 53115
Phone: (262)728-1900 or (800)252-5200 Fax: (262)728-4904 or (800)252-5012
E-mail: spxpe@spx.com

For more information about our worldwide locations, approvals, certifications, and local representatives, please visit www.spxpe.com.

SPX Corporation reserves the right to incorporate our latest design and material changes without notice or obligation. Design features, materials of construction and dimensional data, as described in this bulletin, are provided for your information only and should not be relied upon unless confirmed in writing.