



AutoBlend Systems Continuous Candy Production

Advantages

- The repeatable accuracy of each line proportioning system ensures precise control of expensive ingredients, resulting in a superior product with uniform quality and composition.
- Once a desired recipe is set, the metering system requires no labor.
- Rapid recipe change-over results in minimal waste.
- Pumpheads are sized to fit all recipe and production requirements.
- Reduction of production costs.

Who Would Benefit?

All candy manufacturers, especially those producing seasonal and promotional products.

Simplified process diagram

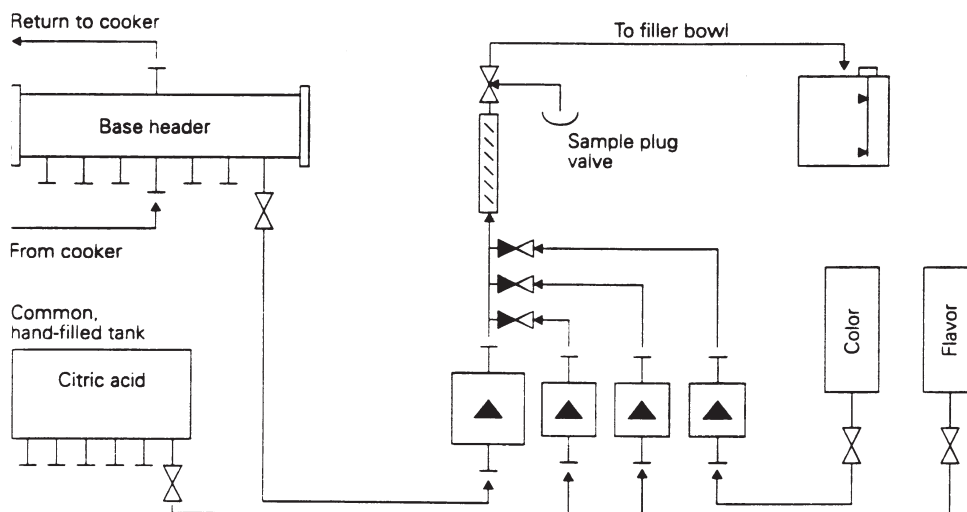

System Operation

- Each lane on the filler line is fed by a four-headed Bran+Luebbe metering pump driven by a common motor.
- The capacity of each pumphead is individually adjustable, either manually, or by remote PLC control.
- Formulation changes can be made on any of the six products without stopping the filler line.

Why should you be interested?

A good percentage of all candy manufacturers are using a Ter-Braak System (see drawing below). Though this Dutch system does incorporate Bran+Luebbe metering pumps, the pumps are not used to their full potential. The configuration of the 13-head pump does not permit individual control of each product. Bran+Luebbe is able to modify these systems by utilizing the color and flavor pumpheads.

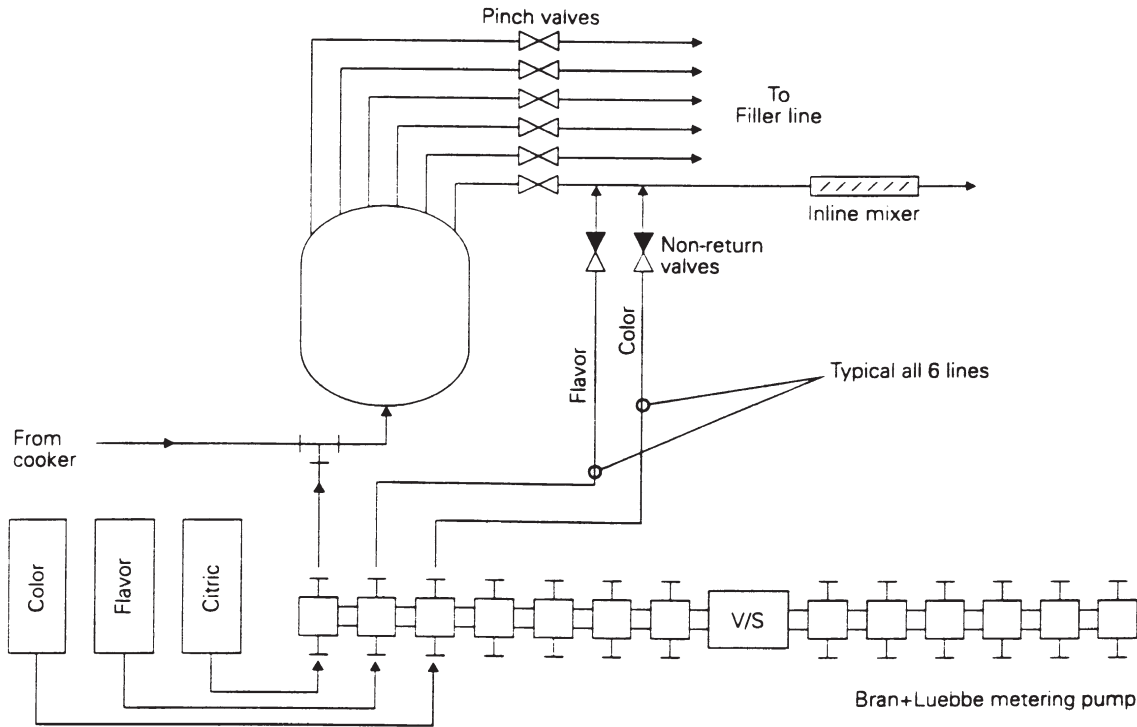

SPX[®]
WHERE IDEAS MEET INDUSTRY

Your local contact:

Bran+Luebbe, An SPX Brand
611 Sugar Creek Road, Delavan, WI 53115
Phone: (800) 252-5200 or (262) 728-1900, Fax: (262) 728-4904
E-mail: bl@spx.com

For more information about our worldwide locations, approvals, certifications, and local representatives, please visit www.branluebbe.com.

SPX Corporation reserves the right to incorporate our latest design and material changes without notice or obligation. Design features, materials of construction and dimensional data, as described in this bulletin, are provided for your information only and should not be relied upon unless confirmed in writing.

Issued: 9/2009 BL-1632

Copyright © 2009 SPX Corporation