



AutoBlend Systems

Bitumen Emulsion Production

Advantages

- High capacity.
- Consistent product quality.
- Cost savings by direct connection to storage tanks.



Bitumen emulsions are used for road surface maintenance.

The emulsion components (bitumen, water, additives and emulsifiers) are taken directly from their storage tanks. The precise metering of each component ensures constant high quality when the mixture passes through the colloid mill to form the emulsion.

Components

- 1 multi-headed metering pumps with manual stroke adjustment, 4 plunger heads (2 double-acting)
- 2 air vessels
- 1 static mixer
- Heating jacket for 2 pump heads and 1 suction-side pipe
- 4 in-line filters

Simplified process diagram

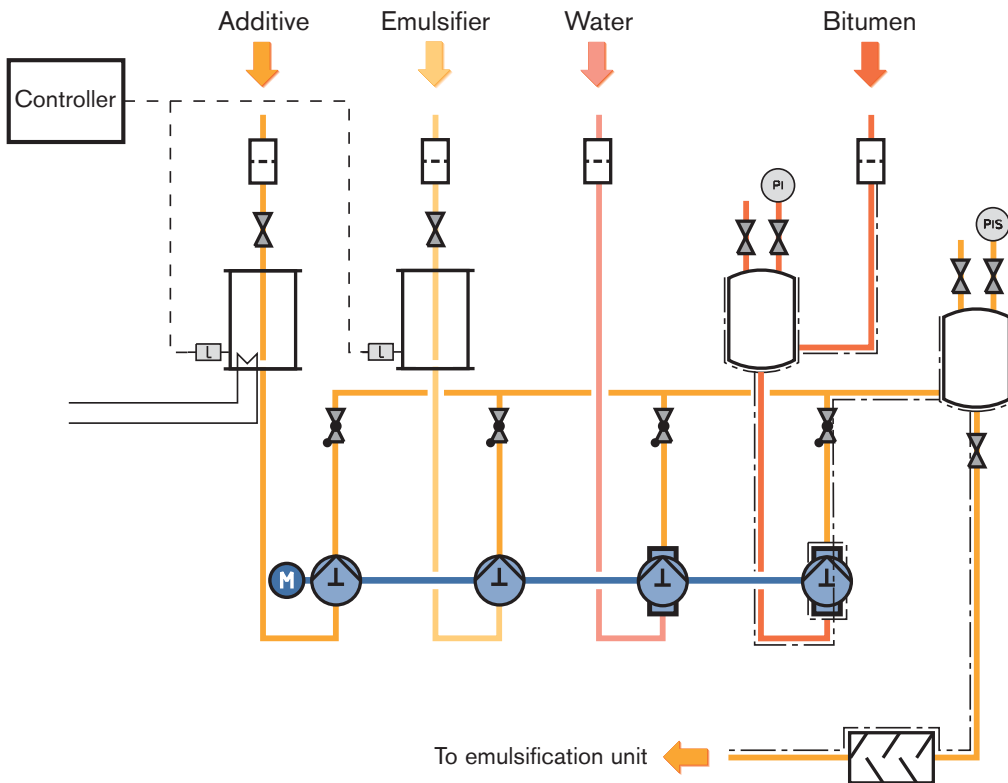

SPX[®]
WHERE IDEAS MEET INDUSTRY

Your local contact:

Bran+Luebbe, An SPX Brand
611 Sugar Creek Road, Delavan, WI 53115
Phone: (800) 252-5200 or (262) 728-1900, Fax: (262) 728-4904
E-mail: bl@spx.com

For more information about our worldwide locations, approvals, certifications, and local representatives, please visit www.branluebbe.com.

SPX Corporation reserves the right to incorporate our latest design and material changes without notice or obligation. Design features, materials of construction and dimensional data, as described in this bulletin, are provided for your information only and should not be relied upon unless confirmed in writing.