

SPX FLOW TECHNOLOGY
NORDERSTEDT GMBH
WERKSTRASSE 4, D-22844 NORDERSTEDT
P.O. BOX 1360, D-22803 NORDERSTEDT
GERMANY
TEL |+49 | 40 522 02 0
FAX |+49 | 40 522 02 444

branluebbe@spx.com

www.spxft.com

QUOTATION

We appreciate your inquiry and quote according to the General Terms and Conditions of Sale 05 recallable until confirmation of order:

Metering Pump Type *ProCam Smart DS15/72* EUR 669,--
Technical Specification acc. to page 2

Conditions of sale: ex works without packing, tax or duties or transport insurance.
Extra price for CIF Job site within Germany/Austria/Switzerland: EUR 65,--.

Terms of payment: 30 days net cash after invoice date.

Validity: These prices are valid for orders received before the 31st. December 2012.

Delivery time ex works Norderstedt: 2 Weeks a.r.o.

Country of origin: Germany
Customs Tariff Number: 84.13.50 40

Warranty: According to item 5 of the "General Terms and Conditions of Sale 05" 24 months after delivery.

Operating manuals: The price includes 1 copy.

SPX Flow Technology Norderstedt GmbH
Sales Bran+Luebbe Pumps & Systems

Technical Specification:

Type / Stroke speed [1/min]	Flowrate [l/h]	max. Pressure [bar]	Connections [female thread ISO228]	Motor [kW / V / Hz]	Idt.Nr
DS15/50	5	20	G 3/8	0,18 / 400 / 50 / IP55	440234
DS15/72	7,5	20	G 3/8	0,18 / 400 / 50 / IP55	440233
DS15/100	10	20	G 3/8	0,18 / 400 / 50 / IP55	440232
DS15/144	15	20	G 3/8	0,18 / 400 / 50 / IP55	440231

The Pump is suitable for the following Operation Parameters:

Pumping Fluid: must be compatible with SS 1.4571/1.4581 and PTFE
 Viscosity: max. 500 mPas
 Specific Gravity: 1 to 2 g/cm³
 Medium-Temperature Range: 0°C to +80°C
 Ambient Temperature Range: 0°C to +40°C

Dimensions:

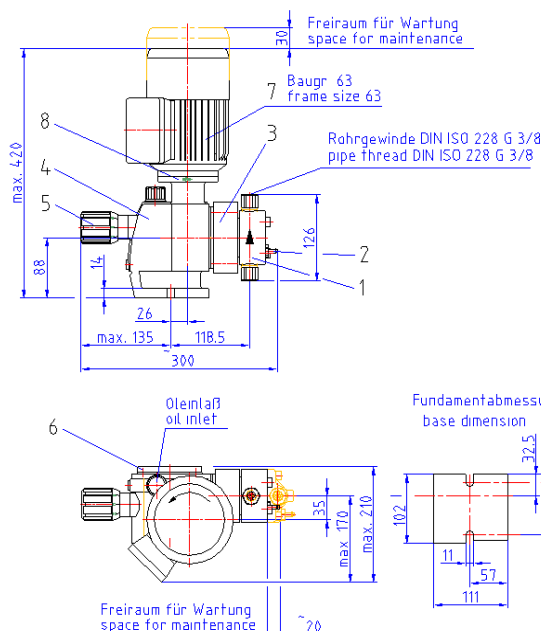

ProCam Smart DS 15

1-Pump Head / 2-Diaphragm Condition Monitoring / 3- Pump Yoke / 4- Gear Box / 5-Vernier Scale Stroke Adjuster / 6- Cover / 7-Motor / 8-Motor Adaptor Flange

Paint Work: Yellow-Green (RAL 6018)